

**HOLLOW  
METAL  
MANUAL**

AMERICAN NATIONAL STANDARD

ANSI/  
NAAMM

**HMMA 867-06**

METAL DOORS & FRAMES



ANSI/NAAMM HMMA 867-06  
March 27, 2006

GUIDE SPECIFICATIONS  
FOR COMMERCIAL  
LAMINATED CORE  
HOLLOW METAL  
DOORS AND FRAMES

ANSI/NAAMM HMMA 867-06  
March 27, 2006



METAL DOORS & FRAMES



Approval of an American National Standard requires verification by ANSI that the requirements for due process, consensus and other criteria for approval have been met by the standards developer.

Consensus is established when, in the judgement of the ANSI Board of Standards Review, substantial agreement has been reached by directly and materially affected interests. Substantial agreement means much more than a simple majority, but not necessarily unanimity. Consensus requires that all views and objections be considered, and that a concerted effort be made toward their resolution.

The use of American National Standards is completely voluntary; their existence does not in any respect preclude anyone, whether they have approved the standards or not, from manufacturing, marketing, purchasing, or using products, processes, or procedures not conforming to the standards.

The American National Standards Institute does not develop standards and will in no circumstances give an interpretation of any American National Standard. Moreover, no person shall give the right or authority to issue an interpretation of an American National Standard in the name of the American National Standards Institute. Requests for interpretation should be addressed to the sponsor whose name appears on the title page of this standard.

**CAUTION NOTICE:** This American National Standard can be revised or withdrawn at any time. The procedures of the American National Standards Institute require that action be taken periodically to reaffirm, revise, or withdraw this standard. Purchasers of American National Standards can receive current information on all standards by calling or writing the American National Standards Institute.

This standard was developed by representative members of the Hollow Metal Manufacturers Association Division (HMMA) of the National Association of Architectural Metal Manufacturers (NAAMM) to provide their opinion and guidance on the specification and use of commercial laminated core hollow metal doors and frame product. This standard contains advisory information only and is published as a public service by NAAMM and its HMMA Division.

***NAAMM and its HMMA Division disclaim all liability of any kind for the use, application, or adaptation of material published in this standard.***

*Current information on all NAAMM Standards is available by calling, writing, or visiting the website of the National Association of Architectural Metal Manufacturers, [www.naamm.org](http://www.naamm.org).*

**National Association of Architectural Metal Manufacturers**

8 South Michigan Avenue  
Chicago, Illinois 60603  
Tel: 312-322-0405 • Fax: 312-332-0706  
[www.naamm.org](http://www.naamm.org)

# TABLE OF CONTENTS

---

Foreword.....	ii
---------------	----

## Part 1 – GENERAL

1.01 Summary .....	1
1.02 Products Provided Under This Section .....	1
1.03 Related Sections .....	1
1.04 References .....	2
1.05 Testing and Performance .....	4
1.06 Quality Assurance .....	5
1.07 Submittals .....	5

## Part 2 – PRODUCTS

2.01 Hollow Metal Doors.....	6
2.02 Hollow Metal Panels.....	9
2.03 Hollow Metal Frame Product .....	9
2.04 Manufacturing Tolerances .....	13
2.05 Hardware Locations .....	14
2.06 Finish.....	15

## Part 3 – EXECUTION

3.01 Site Storage and Protection of Materials.....	15
3.02 Installation .....	15
3.03 Clearances .....	17

Figures.....	18
--------------	----

## APPENDIX (Not part of the Standard)

Steel Tables, HMMA-803-97.....	A1
Grouting Hollow Metal Frames, HMMA-820 TN01-03.....	A2
Defining Undercuts, HMMA-810 TN01-03 .....	A3
Thermal Insulating Values for Door Core Materials .....	A5

# FOREWORD

---

These specifications have been prepared in accordance with the CSI recommended format with Part 1 - General, Part 2 - Product, and Part 3 - Execution. Guide specifications are intended to be used as the basis for developing project specifications and must be edited to suit specific project requirements. Inapplicable provisions should be deleted, appropriate selections should be made where there are choices, and provisions applicable to the project should be added where necessary. Options are shown in brackets. Notes, recommendations and instructions to specifiers are given in italics directly following or at the start of the sections to which they apply. Notes that contain permissive language are not considered part of the standard. Dates given with ASTM and other standards were current at the time this specification was published. When a more recent standard is available, the specifier should verify applicability to this guide prior to its inclusion. *While the CSI Section Format locates Delivery, Storage and Handling in Part 1, NAAMM Standards include them under Part 3 - Execution.*

Materials and fabrication methods are specified in detail in Part 2. Doors and frame product made in accordance with these specifications have successfully met the testing and performance requirements of Section 1.05. However, the materials and fabrication methods called for in these specifications, while providing a guide, are not meant to restrict the use of other materials and methods where it can be demonstrated through the specific testing procedures in Section 1.05 that the construction can equal or exceed the performance levels specified in this Section. In order to ensure that a manufacturer's product meets the desired performance levels, the project specifications must always include the Testing and Performance requirements of Section 1.05 and the Quality Assurance requirements of Section 1.06.

The values stated in inch-pound units are to be regarded as the standard. Corresponding metric values are included in parenthesis for reference purposes only.

This guide specification addresses the requirements for commercial, laminated core, steel doors, and appropriate frame products, and reflects the growing choices of steel door and frame constructions available from member manufacturers.

For welded steel stiffened doors in similar applications, refer to HMMA 860, "Guide Specifications for Hollow Metal Doors and Frames". For commercial steel doors expected to be subjected to a more rigorous level of use, it is recommended that ANSI/NAAMM HMMA 861, "Guide Specifications for Commercial Hollow Metal Doors and Frames", be used. If security is a factor there are two hollow metal standards available; ANSI/NAAMM HMMA 862, "Guide Specifications for Commercial Security Hollow Metal Doors and Frames", and ANSI/NAAMM HMMA 863, "Guide Specifications for Detention Security Hollow Metal Doors and Frames". For acoustic applications consideration may be given to ANSI/NAAMM HMMA 865, "Guide Specification for Swinging Sound Control Hollow Metal Doors and Frames". For situations where corrosion resistance, beyond that of typical commercial steel door and frame applications, or where specialized aesthetic appearance are significant design criteria, consideration should be given to ANSI/NAAMM HMMA 866, "Guide Specifications for Stainless Steel Hollow Metal Doors and Frames".

The CSI Master Format '95, which placed Hollow Metal Doors and Frames in Section 08110 has been relocated in Master Format 2004. Section 08 11 13 is the new CSI location for hollow metal doors and frame products. This Specification presents the 2004 Format as its primary reference, with the '95 Format in parenthesis as a cross-reference. Specifiers can use either, however, both systems shall not be utilized within the same set of construction documents.

CSI BROADSCOPE SECTION 08 11 13 (08110)  
COMMERCIAL LAMINATED CORE HOLLOW METAL  
DOORS AND FRAMES

**PART 1 - GENERAL**

**1.01 SUMMARY**

This section includes hollow metal products, including doors, panels, frames, transom frames, sidelight and window assemblies as shown in the contract documents.

**1.02 PRODUCTS PROVIDED UNDER THIS SECTION**

- A. Commercial, laminated core, hollow metal doors, swinging type, flush or embossed faces, including [glass moldings and stops] [louvers] [louver inserts] [other], as shown in the approved submittal drawings.
- B. Commercial hollow metal panels, fixed or removable, flush or rabbeted, similar in construction to hollow metal doors.
- C. Commercial hollow metal frames, transom frames, sidelight and window assemblies, including [glass moldings and stops] [louvers] [louver inserts] [hollow metal in-fill panels] [other], as shown in the approved submittal drawings.

**1.03 RELATED SECTIONS**

- A. Section 01 56 00 [ ] - Site Protection of Materials
- B. Section 01 66 00 [ ] - Site Storage of Materials
- C. Section 05 10 00 [ ] - Lintels, Posts, Columns or Other Load Bearing Elements
- D. Section 06 10 00 [ ] - Installation of Commercial Hollow Metal Doors and Frames into Other than Steel Stud Partitions
- E. Section 08 11 19 [08130] - Stainless Steel Hollow Metal Doors and Frames
- F. Section 08 34 53 [08113] - Commercial Security Hollow Metal Doors and Frames
- G. Section 08 34 73 [08348] - Swinging Sound Control Hollow Metal Doors and Frames
- H. Section 08 71 00 [08700] - Builders Hardware
- I. Section 08 71 00 [08720] - Weather Stripping and Seals
- J. Section 08 80 00 [08800] - Glass and Glazing Material
- K. Section 09 20 00 [ ] - Installation of Commercial Hollow Metal Doors and Frames into Steel Stud Partitions
- L. Section 09 90 00 [09900] - Field Painting
- M. Section 11 19 00 [11190] - Detention Security Hollow Metal Doors and Frames
- N. Section [ ] - Assembly of Knocked-Down or Slip-On Hollow Metal Frames
- O. Section [ ] - Field Measurements

*This specification covers only those products listed in Section 1.02. Not included in Section 08 11 13 [08110] are builders or rough hardware of any kind, weather-stripping, gaskets, items furnished by others, field painting, or protection at the building site of products furnished under this Section.*

## 1.04 REFERENCES

*The publications listed in this Section form a part of this specification to the extent referenced. The publications are referenced in the text by basic designation only. When a more recent standard is available, the specifier should verify its applicability to this Guide prior to its inclusion.*

- A. ANSI A250.4-2001, Test Procedure and Acceptance Criteria for Physical Endurance for Steel Doors, Frames and Hardware Reinforcings
- B. ANSI A250.10-1998 (R2004), Standard Test Procedure and Acceptance Criteria for Prime-Painted Steel Surfaces for Steel Doors and Frames
- C. ANSI/NAAMM HMMA 801-05, Glossary of Terms for Hollow Metal Doors and Frames
- D. ANSI/NAAMM HMMA 866-01, Guide Specifications for Stainless Steel Hollow Metal Doors and Frames
- E. ANSI/NFPA 80-1999, Standard for Fire Doors and Fire Windows
- F. ANSI/NFPA 105-2003, Standard for the Installation of Smoke Door Assemblies
- G. ANSI/NFPA 252-2003, Standard Methods of Fire Tests of Door Assemblies
- H. ANSI/NFPA 257-2000, Standard on Fire Test for Window and Glass Block Assemblies
- I. ANSI/UL 9-2005, Fire Tests of Window Assemblies, 8<sup>th</sup> Edition
- J. ANSI/UL 10B-2001, Fire Tests of Door Assemblies, 9<sup>th</sup> Edition
- K. ANSI/UL 10C-2001, Positive Pressure Fire Tests of Door Assemblies, 1st Edition
- L. ANSI/UL 1784-2004, Air Leakage Tests of Door Assemblies, 3<sup>rd</sup> Edition
- M. ASTM A 653/A 653M-05, Specification for Steel Sheet, Zinc-Coated (Galvanized) or Zinc-Iron Alloy Coated (Galvannealed) by the Hot-Dip Process
- N. ASTM A 1008/A 1008M-05, Specification for Steel, Sheet, Cold-Rolled, Carbon, Structural, High-Strength Low-Alloy, High-Strength Low-Alloy with Improved Formability, Solution Hardened, and Bake Hardenable
- O. ASTM A 1011/A 1011M-05, Specification for Steel, Sheet and Strip, Hot-Rolled, Carbon, Structural, High-Strength Low-Alloy and High-Strength Low-Alloy with Improved Formability
- P. ASTM C 143/A 143M-05, Test Method for Slump of Hydraulic-Cement Concrete
- Q. ASTM C 578-03, Specification for Rigid, Cellular Polystyrene Thermal Insulation
- R. ASTM C 591-01, Specification for Unfaced Preformed Rigid Polyisocyanurate Thermal Insulation
- S. ASTM C 1289-03, Specification for Faced Rigid Cellular Polyisocyanurate Thermal Insulation Board
- T. ASTM D 1622-03, Standard Test Method for Apparent Density of Rigid Cellular Plastics
- U. CAN4-S104-M80, Standard Method for Fire Tests of Door Assemblies
- V. CAN4-S106-M80, Standard Method for Fire Tests of Window and Glass Block Assemblies
- W. ICBO UBC 7-2 (1997), Fire Tests of Door Assemblies
- X. ICBO UBC 7-4 (1997), Fire Test of Window Assemblies
- Y. NAAMM HMMA 802-92, Manufacturing of Hollow Metal Doors and Frames
- Z. NAAMM HMMA 803-97, HMMA Steel Tables
- AA. NAAMM HMMA 810-87, Hollow Metal Doors
- AB. NAAMM HMMA 810 TN01-03, Defining Undercuts
- AC. NAAMM HMMA 820-87, Hollow Metal Frames

- AD. NAAMM HMMA 820 TN01-03, Grouting Hollow Metal Frames
- AE. NAAMM HMMA 830-02, Hardware Selection for Hollow Metal Doors and Frames
- AF. NAAMM HMMA 831-97, Recommended Hardware Locations for Hollow Metal Doors and Frames
- AG. NAAMM HMMA 840-99, Guide Specifications for Installation and Storage of Hollow Metal Doors and Frames
- AH. NAAMM HMMA 850-00, Fire-Rated Hollow Metal Doors and Frames

*The following standards are used only for 'traditional' (neutral pressure) fire test methods and should be deleted from project specifications when 'positive pressure' is required by the governing building code: NFPA-252 (1.04.G), NFPA-257 (1.04.H), UL 10B (1.04.J), CAN4-S104 (1.04.U) and CAN4-S106 (1.04.V).*

*Conversely, the following standards are used for 'positive pressure' fire tests, and should be deleted from project specifications requiring 'traditional' (neutral pressure) fire tests: UL 10C (1.04.K), UBC 7-2 (1.04.W) and UBC 7-4 (1.04.X).*

*UL 9 (1.04.I) references both 'traditional' (neutral pressure) and 'positive pressure' fire test methods, and as such should be included in all project specifications, except those requiring compliance with Canadian Building Codes.*

*Only project specifications requiring compliance with Canadian Building Codes should include CAN4-S104 (1.04.U) and CAN4-S106 (1.04.V).*

- ANSI American National Standards Institute, Inc.  
25 West 43rd Street  
New York, NY 10036  
(212) 642-4900 [www.ansi.org](http://www.ansi.org)
- ASTM ASTM International  
100 Barr Harbor Drive  
West Conshohocken, PA 19428-2959  
(610) 832-9585 [www.astm.org](http://www.astm.org)
- ICBO International Code Council – Los Angeles Office  
Formerly known as International Conference of Building Officials  
Uniform Building Code  
5360 Workman Mill Road  
Whittier, CA 90601-2298  
(562) 692-4226 [www.icbo.org](http://www.icbo.org)
- NAAMM National Association of Architectural Metal Manufacturers  
8 South Michigan Avenue  
Suite 1000  
Chicago, IL 60603  
(312) 332-0405 [www.naamm.org](http://www.naamm.org)
- NFPA National Fire Protection Association  
1 Batterymarch Park  
P. O. Box 9101  
Quincy, MA 02269  
(617) 770-3000 [www.nfpa.org](http://www.nfpa.org)
- UL Underwriters Laboratories, Inc.  
333 Pfingsten Road  
Northbrook, IL 60062  
(847) 272-8800 [www.ul.com](http://www.ul.com)



## 1.05 TESTING AND PERFORMANCE

### A. Physical Endurance Performance Test for Commercial Laminated Core Hollow Metal Doors

1. The test specimen shall be a 3 ft. x 7 ft. (914 mm x 2134 mm), 1-3/4 in. (44 mm) thick nominal size door, representative of the construction and material to be provided.
2. The specimen shall be tested in accordance with the ANSI A250.4 Cycle and Twist Test procedures.
  - a. Cycle Test Acceptance Criteria: Doors specified with 0.042 in. (1.0 mm) and thicker face sheets shall be tested to Level A (1,000,000 cycles). Doors specified with 0.032 in. (0.8 mm) face sheets shall be tested to Level C (250,000 cycles).
  - b. Twist Test Acceptance Criteria: Maximum deflection under 300 pound (136.1 kg) load for doors specified with 0.042 in. (1.0 mm) and thicker face sheets shall not exceed 1.25 in. (31.7 mm) and maximum permanent deflection shall not exceed 0.125 in. (3.1 mm). Maximum deflection under 300 pound (136.1 kg) load for doors specified with 0.032 in. (0.8 mm) face sheets shall not exceed 2.5 in. (63.5 mm) and maximum permanent deflection shall not exceed 0.125 in. (3.1 mm).
  - c. Test Reports or Certificates of Compliance shall include a description of the test specimen, procedures used in testing, and indicate compliance with the contract document specified acceptance criteria.

### B. Labeled Fire-Rated and/or Smoke and Draft Control Doors and Frame Product

1. Doors, frames, transom and sidelight assemblies provided for openings requiring fire protection, temperature rise and/or smoke and draft control shall be listed and/or classified, and shall bear the label of a recognized testing agency having a factory inspection service. The products shall be tested in accordance with [ANSI/NFPA 252 or ANSI/UL 10B or CAN4-S104] [UL 10C or UBC 7-2; Part 1] [UL 1784 or UBC 7-2; Part 2 or ANSI/NFPA 105] and constructed as listed or classified for labeling. Fire, temperature rise and/or smoke and draft control ratings shall be determined and scheduled by the Architect.
2. Window frames provided for openings requiring fire protection shall be listed and shall bear the label of a recognized testing agency having a factory inspection service. The frames shall be tested in accordance with ANSI/UL 9 or [ANSI/NFPA 257 or CAN4-S106] [UBC 7-4] and constructed as listed for labeling. Fire and/or smoke and draft control ratings shall be determined and scheduled by the Architect.

*UL 10C, UBC 7-2; Part 1, and UBC 7-4 provide for positive pressure testing to accommodate the requirements of some jurisdictions and should be included only for such.*

*UL 1784, UBC 7-2; Part 2 and ANSI/NFPA 105 provide for smoke and draft control assembly testing to accommodate these specific requirements, and should be included only when required.*

*Include CAN4-S104 and CAN4-S106 only for projects requiring conformance with Canadian Building Codes.*

3. If any door or frame product specified by the Architect to be fire-rated cannot qualify for labeling because of design, hardware or any other reason, the Architect shall be so advised in the submittal documents or prior to the manufacturer of product if hardware, glazing or other options affecting the fire-rating are unknown at the time of submittal drawing preparation.

*For additional information refer to NAAMM HMMA 850, "Fire-Rated Hollow Metal Doors and Frames".*

### C. Prime Paint Performance (ANSI A250.10)

1. Sheet steel specimens, with the product manufacturer's production primer, replicating Finish 'as shipped', shall be tested in accordance with ANSI A 250.10.



2. Performance shall meet the Acceptance Criteria described in ANSI A250.10.
3. Test Reports or Certificates of Compliance shall include a description of the test specimen, procedures used in testing, and indicate compliance with the contract document specified acceptance criteria.

## 1.06 QUALITY ASSURANCE

### A. Manufacturer's Qualifications

1. Manufacturer shall provide evidence of having personnel and plant equipment capable of fabricating hollow metal door and frame product of the types specified.
2. The manufacturer shall provide evidence of having a written quality control system in place.

### B. Quality Criteria

1. All door and frame product shall meet the requirements of Section 1.05 of these specifications. Fabricate assemblies in strict accordance with the approved submittal drawings.
2. Fabrication methods and product quality shall meet standards set by the Hollow Metal Manufacturers Association, HMMA, a Division of the National Association of Architectural Metal Manufacturers, NAAMM, as set forth in the contract documents and NAAMM's HMMA 800 through 850 Series documents.

## 1.07 SUBMITTALS

### A. Submittal Drawings

1. Show dimensioned door and frame product elevations and sections.
2. Show listing of opening descriptions including locations, thickness, and anchors.
3. Show location and details of openings.

### B. Samples (if required)

1. Door: 1 ft. x 1 ft. (305 mm x 305 mm) corner section with hinge preparation showing top and internal construction.
2. Frame: 1 ft. x 1 ft. (305 mm x 305 mm) section showing assembled corner joint at head and jamb. Include hinge reinforcement [and grout guard] in one rabbet. When glazed frame product is specified, glazing stop, applied as specified, shall be installed in the opposite rabbet. Glazing stop shall be applied to both head and jamb section to show their intersection.
3. All samples submitted shall be of the production type and shall represent in all respects the minimum quality of work to be furnished by the manufacturer. No work represented by the samples shall be fabricated until the samples are approved and any degradation of fabrication quality, compared to the samples, is cause for the rejection of the work.

### C. The contractor responsible for coordination and installation of products covered under this Section shall;

1. Verify and provide to the manufacturer, actual opening sizes and site conditions by field measurement before fabrication. Submittal drawings shall reflect measurements and conditions provided, and product manufactured accordingly. Coordinate field measurements with fabrication and construction schedules to avoid delays.
2. Verify that substrate conditions, whether existing or installed under other Sections, are as detailed in the architect's drawings, and are acceptable for product installation in accordance with the manufacturer's instructions.

### D. Manufacturer shall not proceed with fabrication without receipt of approved submittal drawings and approved hardware schedules.

*The approved submittal drawings and the approved hardware schedules are the versions that have been provided to the hollow metal manufacturer at the time of release for fabrication. These drawings and schedules are considered part of the project contract documents.*

- E. The contractor responsible for the coordination of procuring products provided under this Section and Section 1.03 - Related Sections, shall comply with the hollow metal door and frame manufacturer's ordering instructions and lead time requirements to avoid delays.

## **PART 2 - PRODUCTS**

### **2.01 HOLLOW METAL DOORS**

#### **A. Materials**

##### **1. Steel**

*ANSI and ASTM Standards no longer utilize 'gage' to define steel thickness. In this Specification steel is expressed in terms of minimum decimal inch (millimeter) thickness. Dimensions or sizes traditionally expressed in fractional inches are shown in decimal inches (millimeters). HMMA has developed a series of Tables, (NAAMM/HMMA 803), included as Appendix 1 of this Specification, to summarize the imperial standards and their corresponding metric values.*

- a. Doors shall be manufactured from cold-rolled steel conforming to ASTM A1008/A 1008M CS Type B, or galvanized steel conforming to ASTM A 653/A 653M CS Type B Coating Designation A25 (ZF75), or hot-rolled, pickled and oiled (HRPO) steel conforming to ASTM A 1011/A 1011M CS Type B. Steel shall be free of scale, pitting, coil breaks, surface blemishes, buckles, waves or other defects.
- b. Interior Doors: Face sheets shall be [0.032 in. (0.08 mm)] [0.042 in. (1.0 mm)] [0.053 in. (1.3 mm)] minimum thickness.

*For interior doors subject to corrosive conditions it is recommended that zinc-coated face sheets, as specified in 2.01.A.1.c, be used.*

- c. Exterior Doors: Face sheets shall be [0.042 in. (1.0 mm)] [0.053 in. (1.3 mm)] minimum thickness zinc-coated steel conforming to ASTM A 653/A653M CS Type B, Coating Designation A60 (ZF180) or G60 (Z180).

*For doors subject to severely corrosive conditions it is recommended that stainless steel products, as detailed in NAAMM's ANSI/NAAMM HMMA 866, "Guide Specifications for Stainless Steel Hollow Metal Doors and Frames", be utilized.*

##### **2. Door Cores**

- a. Honeycomb: "kraft" paper hexagonal cells
- b. Polyisocyanurate: Rigid, pre-formed, closed cell board, conforming to ASTM C 591 (unfaced) or ASTM C 1289 (faced).
- c. Polystyrene: Rigid, extruded, closed cell board, 1 pound per cubic foot (16 kilograms per cubic meter) density minimum, conforming to ASTM C 578, Type 1.
- d. Polyurethane: Rigid, cellular type, board conforming to ASTM D 1622, or foamed-in-place, 1.8 pound per cubic foot (29 kilograms per cubic meter) density minimum, containing no urea formaldehyde resins.
- e. Steel Stiffened: Continuous vertical formed steel sections, 0.026 in. (0.6 mm) minimum thickness, spaced with interior webs not more than 6 in. (152 mm) apart, which upon assembly, span the full thickness of the interior of the door. Voids between stiffeners shall be filled with fiberglass or mineral rock-wool batt-type material.
- f. Temperature Rise Rated (TRR) Fire Doors: Internal construction in accordance with the individual manufacturer's listings.
- g. Alternate proprietary laminated core materials, engineered, tested and meeting the performance and quality requirements of Sections 1.05 and 1.06 shall be permitted.

## B. Construction

1. Doors shall be the types, sizes and construction, in accordance with the contract documents and shall meet the performance requirements of Section 1.05. Prior to shipment, mark each door with an identification number as shown on the approved submittal drawings.
2. Door faces shall have no visible seams.
3. Door Edges
  - [a. Door face sheets shall be joined at their vertical edges by a continuous weld extending the full height of the door, filled and sanded, with no visible seam at their vertical edges.]

*See "Welded, Continuously" in ANSI/NAAMM HMMA 801, "Glossary of Terms for Hollow Metals Doors and Frames"*

[or]
  - [b. Door face sheets shall be joined at their vertical edges by a continuous interlocking or lock-tab seam the full height of the door, with [a visible] [no visible] seam at their vertical edges.]

*Interlocking and lock-tab doors with no visible edge seam can be used for aesthetic appearance as a design consideration.*

[or]
  - [c. Door face sheets shall be joined by projection, spot or tack welds at their vertical edges, 6 in. (152 mm) on center maximum spacing, such that there are no visible welds or weld markings on the exposed door edges, presenting a visible vertical seam at both door edges.]

*Not all doors edges are available with all core materials, or from all member manufacturers. Specifiers should consult member manufacturers to determine availability.*
4. Minimum nominal door thickness shall be 1-3/4 in. (44 mm). Edge bends shall be true and straight and of minimum radius for the thickness of metal used.
5. Cores
  - a. Interior doors shall be stiffened with a [honeycomb] [or] [polyisocyanurate] [or] [polystyrene] [or] [polyurethane] [or] [steel stiffened] [or] [other] core, spanning the full thickness of the interior of the door, laminated under pressure to each face sheet.
  - b. Exterior doors shall be stiffened with a [honeycomb] [or] [polyisocyanurate] [or] [polystyrene] [or] [polyurethane] [or] [steel stiffened] [or] [other] core, spanning the full thickness of the interior of the door, laminated under pressure to each face sheet.

*Refer to Appendix 4 for additional information on the thermal insulating values of door cores.*
  - c. Where determined and scheduled by the Architect, temperature rise rated (TRR) fire doors shall be sufficiently insulated to limit the temperature rise on the "unexposed" side of the door, as required by the governing building code.
6. The top and bottom edges shall be closed with a continuous steel channel not less than 0.053 in. (1.3 mm) thickness spot welded or laminated to both face sheets.
7. Exterior doors, and where otherwise scheduled by the Architect, shall be closed flush at the top edge. Where required for the attachment of weather-stripping, a flush steel closure channel shall be provided at the bottom edge. Openings shall be provided in the bottom closure channel of exterior doors to permit the escape of entrapped moisture.
8. Edge profiles shall be provided on both vertical edges of doors as follows, unless hardware dictates otherwise:
  - a. Single acting doors;
    - i. Hinge edge; beveled 1/8 in. in 2 in. (3.1 mm in 50.8 mm) or square edge

- ii. Lock edge; beveled 1/8 in. in 2 in. (3.1 mm in 50.8 mm)
  - b. Double acting doors; rounded on 2-1/8 in. (54 mm) radius
- 9. Hardware Reinforcements and Preparations
  - a. Doors shall be mortised, reinforced, drilled and tapped at the factory for templated hardware only, in accordance with the approved hardware schedule and templates provided by the hardware supplier. Where surface mounted hardware, anchor hinges, thrust pivots, pivot reinforced hinges, or non-templated hardware apply, doors shall be reinforced, with drilling and tapping done by others in the field.
  - b. Minimum steel thickness for hardware reinforcements shall be as follows:
    - i. Full mortise hinges and pivots..... 0.167 in. (4.2mm) or 0.123 in. (3.1 mm) angle or channel shaped type
    - ii. Lock fronts and strikes..... 0.067 in. (1.7 mm) or 0.053 in. (1.3 mm) unitized reinforcement with extruded tapped holes that provide equivalent number of threads as 0.067 in. (1.7 mm)
    - iii. Concealed holders..... 0.093 in. (2.3 mm)
    - iv. Internal reinforcements for other surface applied hardware ..... 0.053 in. (1.3 mm)
  - c. In cases where electrically or electronically operated hardware is required, and indicated on the approved hardware schedule, conduit, hardware enclosures, and/or junction boxes within the door shall be provided. Access plates, where required, shall be the same material and thickness as the door face sheets and shall be fastened with not less than four (4) #8-32 machine screws or #6 sheet metal screws at a spacing not to exceed 12 in. (305 mm) on center.
- 10. Glazing Moldings and Stops
  - a. Where specified or scheduled, doors shall be provided with steel moldings to secure glazing materials, furnished and installed in the field by others, in accordance with glazing sizes and thickness shown in the contract documents.
  - b. Fixed moldings or integral stops, not less than 0.032 in. (0.8 mm) thickness, shall be provided on the secure side of the door.
  - c. Removable or snap-on stops shall be not less than 0.032 in. (0.8 mm) thickness, with tight fitting butt or mitered corners.
  - d. Snap-on moldings shall be designed with a non-removable stop on the secure side of the door after glazing installation.
  - e. Metal surfaces to which glazing stops are applied, and the inside of the glazing stops, shall be treated for maximum paint adhesion and painted with a rust inhibitive primer prior to installation in the door, or shall be fabricated from zinc-coated steel conforming to ASTM A 653/A 653M, A40 (ZF120) for interior doors, A60 (ZF180) or G60 (Z180) for exterior openings.
- 11. Where specified in the contract documents, doors shall be provided with louvers.
  - a. Louvers for non-fire rated doors shall be welded inverted V type, Y type, or face pierced construction, or louver inserts may be provided.
  - b. Inverted V and Y type vanes shall be not less than 0.042 in. (1.0 mm) thickness.
  - c. Fire-rated doors shall be factory prepared for listed, automatic closing, fusible link, fire door louvers, in accordance with the individual door manufacturer's listings. Installation shall be in accordance with the louver manufacturer's listings and installation instructions.
  - d. Louvers for exterior doors shall be provided with insect and/or bird screens.

## 2.02 HOLLOW METAL PANELS

- A. Hollow metal panels, 1-3/4 in. (44 mm) nominal thickness, shall be made of the same materials and construction as specified in Section 2.01 of this specification.
- B. Hollow metal panels shall be finished as specified in Section 2.06 of this specification.

## 2.03 HOLLOW METAL FRAME PRODUCT

*Provisions of Section 2.03 are applicable to frames, transom frames, sidelight and window assemblies, unless indicated otherwise.*

### A. Materials

- 1. Frame product shall be manufactured from cold-rolled steel conforming to A1008/A 1008M CS Type B, or galvaneal steel conforming to ASTM A 653/A 653M CS Type B Coating Designation A25 (ZF75), or hot-rolled and pickled and oiled (HRPO) steel conforming to ASTM A 1011/A 1011M CS Type B.
- 2. Interior Frame Product: Profiles shall be not less than 0.053 in. (1.3 mm) thickness for frame product that receive hollow metal or solid core wood doors [, 0.042 in. (1.0 mm) for frames that receive hollow core wood doors].

*For interior areas subject to corrosive conditions it is recommended that zinc-coated frame product, as specified in 2.03.A.3, be used.*

- 3. Exterior Frame Product: Profiles shall be not less than 0.053 in. (1.3 mm) thickness, zinc-coated steel conforming to ASTM A 653/A 653M CS Type B, Coating Designation A60 (ZF180) or G60 (Z180).

*For frame product subject to severely corrosive conditions it is recommended that stainless steel products, as detailed in NAAMM's ANSI/NAAMM HMMA 866, "Guide Specifications for Stainless Steel Hollow Metal Doors and Frames", be utilized.*

### B. Construction

- 1. Frames shall be [welded] [or] [knocked-down] [or] [slip-on] units. Transom, multi-opening, sidelight and window assemblies shall be welded units. All frame product shall be of the sizes and types shown on the approved submittal drawings. Prior to shipment, mark each frame product with an identification number as shown on the approved submittal drawings. Frame product shall be constructed in accordance with the contract documents and meet the performance criteria specified in Sections 1.05.B and 1.05.C. Frame product shall be constructed in accordance with NAAMM HMMA 820 with regard to joint designs and welding techniques.
- 2. Finished work shall be neat in appearance, square, and free of defects, warps or buckles. Pressed steel members shall be straight and of uniform profile throughout their lengths.
- 3. Jamb, header, mullion and sill profiles shall be in accordance with the frame schedule and as shown on the approved submittal drawings.
- 4. Corner joints shall have all contact edges closed tight, with faces mitered and stops mitered or butted.

#### a. Welded Frame Product

- i. Perimeter face joints (flush or indented) shall be continuously welded internally or externally, and finished smooth with seamless faces.
- ii. Internal flush face joints shall be continuously welded and finished smooth with seamless faces.
- iii. Members at internal indented intersections shall be securely welded to concealed reinforcements, and have hairline face seams.
- iv. All other intersecting elements shall have hairline seams.

*See NAAMM HMMA 820, "Hollow Metal Frames", and Figure 1 of this guide, for further details on frame welding.*

- b. Knocked-Down and Slip-On Frames
  - i. Components shall be shipped unassembled.
  - ii. Flush corner joints shall be factory prepared with steel reinforcing gussets not less than 0.032 in (0.8mm) thickness, and/or integral tabs and slots which securely interlock upon assembly.
  - iii. Corner joint design shall assure component profile alignment and frame performance, when field assembled by others, in accordance with the manufacturer's installation instructions.
5. Thermally Broken Frame Product
  - a. Where indicated in the contract documents, thermally broken frame product shall be provided.
  - b. Interior and exterior sections shall be separated by a continuous thermal break.
  - c. Closed sections shall be factory insulated.
  - d. Insulation for open sections shall be provided by the installer on site.

*Thermally broken frame products are utilized in applications where energy conservation and extreme temperature differences between the building interior and exterior are design factors. The use of insulated hollow metal doors and glazing materials are recommended.*
6. At drywall partitions, welded, knocked-down or slip-on frames may be furnished. At all other partition types, welded, or knocked-down frames shall be provided. Slip-on frames shall be the pressure fit type, installed after the partition is in place.
7. Minimum height of stops shall be 0.625 in. (15.8 mm).
8. Cut-off stops, where specified, shall be capped at heights as shown on the approved submittal drawings [ , and jamb joints below cut-off stops shall be welded, finished smooth so that there are no visible seams].

*It is recommended that cut-off stops not be used at exterior, lead-lined, double egress or gasketed openings.*
9. Each door opening shall be prepared for single stud, resilient door silencers, three (3) per strike jamb for single door openings, two (2) per head for pairs, except on gasketed frame product. Silencers shall be supplied and installed by others.
10. When shipping limitations or site access so dictate, or when advised by the contractor responsible for coordination or installation, frame product for large openings shall be fabricated in sections designated for assembly in the field by others. Alignment plates or angles shall be installed at each joint. Such components shall be the same material and thickness as the frame. Field joints shall be made in accordance with approved submittal drawings and shall be field welded by others.
11. Hardware Reinforcements and Preparations
  - a. Frame product shall be mortised, reinforced, drilled and tapped at the factory for all templated hardware only, in accordance with the approved hardware schedule and templates provided by the hardware supplier. Where surface mounted hardware, anchor hinges, thrust pivots, pivot reinforced hinges, or non-templated hardware apply, frame product shall be reinforced, with drilling and tapping done by others in the field.
  - b. Frame product that receive 1-3/8 in. (35 mm) thick hollow core wood doors shall be:
    - [i. Furnished with one (1) pair of 3-1/2 in. (89 mm) welded-on hinges. One leaf to be welded to frame with door leaf and pin shipped loose for installation on the wood doors by others.]



[or]

- [ii. Factory mortised and reinforced, drilled and tapped for templated hinges furnished by others.]

c. Minimum steel thickness of hardware reinforcing shall be as follows:

- i. Full mortise hinges and pivots ..... 0.167 in. x 1.25 in. x 10 in. length (4.2 mm x 31.7 mm x 254 mm) or 0.123 in. (3.1 mm) thickness angle or channel shaped type
- ii. Strikes ..... 0.093 in. (2.3 mm) or 0.053 in. (1.3 mm) unitized reinforcement with extruded tapped holes that provide equivalent number of threads as 0.093 in. (2.3 mm)
- iii. Flush bolts, closers, hold open arms and other surface applied hardware ..... 0.093 in. (2.3 mm)

12. In cases where electrically or electronically operated hardware is required, and indicated on the approved hardware schedule, conduit, hardware enclosures and/or junction boxes shall be provided. Access plates, where required, shall be the same material and thickness as the frame product and shall be fastened with not less than four (4) #8-32 machine screws or #6 sheet metal screws at a spacing not to exceed 12 in. (305 mm) on center.

13. Floor Anchors

- a. For welded and knocked-down frame product, floor anchors shall be securely welded inside jambs, and provided with two holes for fasteners supplied and installed by others.
- b. Where specified or scheduled, adjustable floor anchors, providing not less than 2 in. (50.8 mm) height adjustment, shall be securely welded inside jambs.
- c. For applications that do not permit the use of a floor anchor, an additional jamb anchor shall be substituted at a location not to exceed 8 in. (204 mm) from the base of the jamb.
- d. Minimum thickness of floor anchors shall be 0.042 in. (1.0 mm).

14. Jamb Anchors

- a. Frame product shall be provided with anchorage appropriate to frame and wall construction.
- b. Masonry Type

Frame product for installation in new masonry walls shall be provided with steel adjustable jamb anchors of the T-strap, stirrup or wire type, not less than 0.053 in. (1.3 mm) thickness or 0.156 in. (3.9 mm) diameter wire. Straps shall be not less than 2 in. x 10 in. (50.8 mm x 254 mm) in size, corrugated and/or perforated. Jamb anchors shall be placed at a maximum of 18 in. (457 mm) from top and bottom of openings. The minimum number, spaced at maximum 32 in. (812 mm) on center, provided on each jamb, based on the overall frame height, shall be as follows:

- i. Up to 60 in. (1524 mm) ..... 2 anchors
- ii. Greater than 60 in. (1524 mm) up to 90 in. (2286 mm) ..... 3 anchors
- iii. Greater than 90 in. (2286 mm) up to 96 in. (2438 mm) ..... 4 anchors



- iv. Greater than 96 in. (2438 mm) ..... 4 anchors plus one for each 24 in. (610 mm) or fraction thereof spaced at 24 in. (610 mm) maximum between anchors

c. Dry Wall Type

Welded and knocked-down frame product for installation in drywall partitions shall be provided with steel jamb anchors of suitable design, not less than 0.042 in. (1.0 mm) thickness, inside each jamb. Jamb anchors shall be placed a maximum of 18 in. (457 mm) from top and bottom of openings. The minimum number, spaced at maximum 32 in. (812 mm) on center, provided on each jamb, based on the over-all frame height, shall be as follows:

- i. Up to 60 in. (1524 mm) ..... 2 anchors
- ii. Greater than 60 in. (1524 mm) up to 90 in. (2286 mm) ..... 4 anchors
- iii. Greater than 90 in. (2286 mm) up to 96 in. (2438 mm) ..... 5 anchors
- iv. Greater than 96 in. (2438 mm) ..... 5 anchors plus one for each 24 in. (610 mm) or fraction thereof spaced at 24 in. (610 mm) maximum between anchors

d. Compression Type

Slip-on frames for installation in stud partitions shall be provided with an adjustable compression anchor in each jamb and provision for secure attachment of each jamb base to stud runners.

e. Expansion Bolt Type

Welded or knocked-down frame product for installation in existing masonry or concrete walls shall be prepared for expansion bolt type anchors. The preparation shall consist of a countersunk hole for a 0.375 in. (9.5 mm) diameter bolt, and a spacer within the jamb profile. Anchors shall be placed a maximum of 6 in. (152 mm) from the top and bottom of the frame, with intermediate spacing at a maximum of 26 in. (660 mm) on center. Bolts and shields for such anchors shall be provided and installed by others.

f. Other Anchor Types

Frame product to be installed in pre-finished concrete, masonry or steel openings shall be provided with anchoring systems of suitable design and quantity, as shown on the approved submittal drawings. Fasteners for such anchors shall be provided and installed by others.

*A pre-finished opening may be one that is constructed as part of another assembly or system (e.g.; precast concrete panel) and which requires anchors similar in performance to those covered by 2.03.B.14.*

- 15. Frame product for installation in masonry walls with door openings greater than 48 in. (1219 mm) in width shall have a steel angle or channel stiffener factory welded into the head, when the head is to be grouted. Such stiffeners shall be not less than 0.093 in. (2.3 mm) thickness, not longer than the door opening width, and shall not be used as lintels or load bearing members.
- 16. Grout guards fabricated from not less than 0.016 in. (0.4 mm) thick steel shall be provided at all hardware mortises on frame product to be grouted.
- 17. All door openings in welded frame product shall be provided with a temporary steel spreader welded to the feet of the jambs or mullions to serve as bracing during shipping and handling, and which shall not be used for installation.

18. In-Fill Panels

- a. Where specified or scheduled, frame product shall be provided with in-fill panels secured to frame sections with removable steel stops.
- b. For non-labeled frame product, in-fill panels shall be constructed from 0.032 in. (0.8 mm) minimum thick sheet steel, of the same type specified for the frame product, laminated to each face of the manufacturer’s standard solid backing.
- c. For fire-rated frame product, in-fill panels shall be constructed from 0.032 in. (0.8 mm) minimum thick sheet steel, of the same type specified for the frame product, laminated to each face of a solid approved backing.

*Refer to NAAMM HMMA 850, “Fire-Rated Hollow Metal Doors and Frames”, for additional information.*

19. Removable Glazing Stops

- a. Where specified, frame product shall be provided with removable stops to secure glazing materials or in-fill panels. Glazing materials shall be furnished and installed in the field by others, in accordance with glazing sizes and thickness shown in the contract documents.
- b. Removable steel channel glazing stops shall be not less than 0.032 in. (0.8 mm) thick, butted at corners and secured to the frame section using cadmium or zinc-plated #6 minimum countersunk sheet metal screws.
- c. The frame section underneath the glazing stops and the inside of the glazing stops shall be treated for maximum paint adhesion and painted with a rust inhibitive primer prior to installation, or shall be fabricated from zinc-coated steel conforming to ASTM A 653/A 653M, A40 (ZF120) for interior applications, A60 (ZF180) or G60 (Z180) for exterior units.
- d. Interior frame product may be provided with snap on glazing stops.

**2.04 MANUFACTURING TOLERANCES**

*The manufacturer of hollow metal door and frame product is responsible only for the manufacturing tolerances listed in 2.04.A. The final clearances and relationship between door and frame depend on the setting of the frame (see Figure 4), and the hanging and adjustment of the door and hardware. See Sections 3.02 and 3.03.*

A. Manufacturing tolerances shall be maintained within the following limits:

1. Frame Product for Singles or Pairs of Doors

- a. Width, measured between rabbets at the head: nominal opening width + 1/16 in (+1.5 mm), - 1/32 in. (- 0.8 mm)
- b. Height (total length of jamb rabbet): nominal opening height ± 3/64 in. (1.2 mm)
- c. Cross sectional profile dimensions (See Figure 2):
  - i. Face ..... ± 1/32 in. (0.8 mm)
  - ii. Stop ..... ± 1/32 in. (0.8 mm)
  - iii. Rabbet ..... ± 1/32 in. (0.8 mm)
  - iv. Depth ..... ± 1/32 in. (0.8 mm)
  - v. Throat ..... ± 1/16 in. (1.5 mm)

*Frame product overlapping walls (except slip-on construction) to have throat dimension 1/8 in. (3.1 mm) greater than dimensioned wall thickness to accommodate irregularities in wall construction.*

2. Doors

Tolerances for actual hollow metal door sizes are as follows:

- a. Width .....  $\pm 3/64$  in. (1.2 mm)
- b. Height .....  $\pm 3/64$  in. (1.2 mm)
- c. Thickness .....  $\pm 1/16$  in. (1.5 mm)
- d. Edge Flatness .....  $1/16$  in. (1.5 mm) maximum
- e. Surface Flatness .....  $1/8$  in. (3 mm) maximum

*Hollow metal doors are undersized to fit the frame's door opening. Edge clearances are based upon individual manufacturer's designs.*

3. Hardware

- a. Cutouts ..... Template dimensions, + 0.015 in. (0.38 mm), - 0
- b. Location .....  $\pm 1/32$  in. (0.8 mm)
- c. Between hinge centerlines .....  $\pm 1/64$  in. (0.4 mm)

**2.05 HARDWARE LOCATIONS**

- A. The location of hardware on doors and frame product shall be as listed below. All dimensions, except the hinge locations, are referenced from the floor, as defined in Section 3.03.B.3.

*When hollow metal frame products are specified for use with doors to be furnished by others, hardware preparations on the doors are normally governed by the location on the frames, as stated in 2.05.A.*

1. Hinges

- a. Top ..... 5 in. (127 mm) from underside frame rabbet at door opening to top of hinge
  - b. Bottom ..... 10 in. (254 mm) from floor to bottom of hinge
  - c. Intermediate ..... centered between top and bottom hinges
  - d. On dutch doors ..... 5 in. (127 mm) from underside of frame rabbet at door opening, to top of upper hinge; 10 in. (254 mm) from floor to bottom of lower hinge and; 5 in. (127 mm) from split line to top and bottom of upper and lower intermediate hinges, respectively
- 2. Locks and latches ..... 38 in. (965 mm) to centerline of knob or lever shaft
  - 3. Deadlocks ..... 46 in. (1168 mm) to centerline of cylinder
  - 4. Exit hardware ..... 38 in. (965 mm) to centerline of cross bar or as shown on hardware template
  - 5. Door pulls ..... 42 in. (1066 mm) to center of grip
  - 6. Push/pull bars ..... 42 in. (1066 mm) to centerline of bar
  - 7. Arm pulls ..... 46 in. (1168 mm) to centerline
  - 8. Push plates ..... 46 in. (1168 mm) to centerline of plate
  - 9. Roller latches ..... 45 in. (1143 mm) to centerline of latch

*See NAAMM/HMMA 830 and 831 for additional information.*

## 2.06 FINISH

- A. After fabrication, all tool marks and surface imperfections shall be filled and sanded as required to make face sheets, vertical edges and weld joints free from irregularities and dressed smooth.
- B. Fully Primed Surfaces  
After appropriate metal preparation to ensure maximum paint adhesion, all exposed surfaces of door and frame product manufactured from cold-rolled, hot-rolled, A25 (ZF75), or G60 (Z180) zinc-coated steel shall receive a factory applied rust inhibitive primer. Product shall meet the performance requirements of Section 1.05.C.
- C. Unprimed Galvanneal Surfaces  
All exposed surfaces of door and frame product manufactured from A40 (ZF120) or heavier zinc-coated galvanneal steel shall have areas where zinc coating has been removed during fabrication touched-up with a zinc-rich rust inhibitive primer or shall receive a factory applied full-coat rust inhibitive primer.

*All primer and finish paint must be formulated for Direct to Metal (DTM) application.*

- D. Primer shall be fully cured prior to shipment.

## PART 3 - EXECUTION

### 3.01 SITE STORAGE AND PROTECTION OF MATERIALS

*Correct site storage and protection are essential to the proper performance of doors and frame product. The requirements for proper storage are given in the following Section. However, it is important to recognize that these are not the responsibility of the hollow metal manufacturer. For this reason the requirements for storage and protection of hollow metal doors and frame product should be included in the Section of the specifications where installation work is specified. For additional information regarding installation see NAAMM HMMA 840, "Guide Specifications for Installation and Storage of Hollow Metal Doors and Frames".*

- A. The contractor responsible for receiving hollow metal door and frame product shall remove wraps or covers upon delivery at the building site and shall ensure that any scratches or disfigurement caused by shipping or handling are promptly cleaned and touched up with a rust inhibitive 'Direct to Metal' (DTM) primer.
- B. The contractor responsible for receiving hollow metal door and frame product shall ensure that materials are properly stored on planks or dunnage in a dry location. Doors and frame product shall be stored in a vertical position, spaced by blocking. Figure 3 illustrates the recommended storage positioning. Materials shall be covered to protect them from damage but in such a manner as to permit air circulation.

### 3.02 INSTALLATION

*Correct installation is essential to the proper performance of doors and frame product. The requirements for proper installation are given in the following Sections. However, it is important to recognize that installation is not the responsibility of the hollow metal manufacturer. For this reason the requirements for installation should be included in the Section of the specifications where installation work is specified. It shall be the responsibility of the general contractor, using experienced personnel, to perform the work outlined below. For additional information regarding installation see NAAMM HMMA 840, "Guide Specifications for Installation and Storage of Hollow Metal Doors and Frames".*

A. The installer shall perform the following:

1. Prior to installation, the area of floor on which the frame is to be installed, and within the path of door swing, shall be checked for flatness.
2. Prior to installation, remove temporary spreaders. Doors and frame product shall be checked for correct size, swing, fire-rating, and opening number.

Prior to installation, all interior surfaces of perimeter frame product sections to be installed in masonry or concrete walls shall be isolated and protected from grout and antifreeze agents.

*The drawbacks and benefits associated with the use of water based masonry grouts, with or without antifreeze agents, should be carefully weighed during the detailing and specification process. Grouting of mullions and other closed sections is not recommended, and plaster based grouts should not be used. Refer to NAAMM's HMMA TechNote, HMMA-820 TN01-03, "Grouting Hollow Metal Frames", in Appendix 2 for further guidance.*

4. During the setting of the frame product check and correct as necessary for opening width, opening height, squareness, alignment, twist and plumbness. Installation tolerances shall be maintained within the following limits:
  - a. Opening width ..... measured from rabbet to rabbet at top, middle and bottom of frame; + 1/16 in. (1.5 mm), - 1/32 in. (0.8 mm)
  - b. Opening height ..... measured vertically between the frame head rabbet and top of floor or bottom of frame minus jamb extension at each jamb and across the head;  $\pm 3/64$  in. (1.2 mm)
  - c. Squareness ..... measured at rabbet on a line from jamb, perpendicular to frame head; not to exceed 1/16 in. (1.5 mm)
  - d. Alignment ..... measured at jambs on a horizontal line parallel to the plane of the face; not to exceed 1/16 in. (1.5 mm)
  - e. Twist ..... measured at opposite face corners of jambs on parallel lines perpendicular to the plane of the door rabbet; not to exceed 1/16 in. (1.5 mm)
  - f. Plumbness ..... measured at jambs on a perpendicular line from the head to the floor; not to exceed 1/16 in. (1.5 mm)

*The above tolerances provide a reasonable guideline for proper installation of hollow metal frame product. However, it should be noted that the cumulative affect of the installation tolerances at or near their maximum levels could result in sufficient misalignment to prevent the door from functioning properly. Installers should be careful not to create a tolerance buildup. Tolerance buildup occurs when several tolerances are at or near their maximums.*

5. The details in Figure 4 illustrate the method of measuring the above specified tolerances.
6. Grout guards and junction boxes are intended to protect hardware mortises and tapped holes from masonry grout of 4 in. (101 mm) maximum slump consistency that is hand troweled in place. If a lighter consistency grout (greater than 4 in. (101 mm) slump, when tested in accordance with ASTM C 143/C 143M) is to be used, special precautions must be taken in the field by the installer to protect the aforementioned.
7. Frame products are not intended or designed to act as forms for grout or concrete. Grouting of hollow metal sections shall be done in "lifts" or precautions shall be otherwise taken by the contractor to ensure that frames are not deformed or damaged by the hydraulic forces that occur during this process.

8. Hollow metal surfaces shall be kept free of grout, tar, and/or other bonding materials or sealers. Grout, tar, and/or other bonding materials or sealers shall be promptly cleaned off of frame product and doors.
9. The installer shall finish and touch-up marks caused by spreader removal.
10. Exposed hollow metal surfaces which have been scratched or otherwise marred during installation, cleaning, and/or field welding, shall promptly be finished smooth, cleaned, treated for maximum paint adhesion and touched up with a rust inhibitive primer comparable to and compatible with the factory applied primer and finish paint specified in Section 09 90 00 [09900]. All touch-up primer and finish paint must be formulated for Direct to Metal (DTM) application.
11. Labeled fire doors and frame product shall be installed in accordance with the terms of their listings, ANSI/NFPA 80, or the local Authority Having Jurisdiction.
12. Proper door edge clearances shall be maintained in accordance with Section 3.03, except for special conditions otherwise noted. Where necessary, metal hinge shims, furnished by the installer, are permitted to maintain clearances.
13. Hardware shall be applied in accordance with hardware manufacturer's templates and instructions.
14. Finish paint in accordance with Section 09 90 00 [09900].
15. Install door silencers.
16. Install glazing materials in accordance with Section 08 80 00 [08800].

### 3.03 CLEARANCES

- A. Edge clearance for swinging hollow metal doors shall provide for the functional operation of the assembly and shall not exceed the following:
  1. Between doors and frame product at head and jambs ..... 3/16 in. (4.7 mm)
  2. Between edges of pairs of doors..... 3/16 in. (4.7 mm)
- B. Floor clearance for swinging hollow metal doors shall not exceed the following:
  1. At bottom of door where a threshold is used ..... 3/8 in. (9.5 mm) from bottom of door to top of threshold
  2. At bottom of door where no threshold is used ..... 3/4 in. (19.1 mm) above floor
  3. Between bottom of door and nominal surface of floor coverings at fire-rated openings, as provided in ANSI/NFPA 80 ..... 1/2 in. (12.7 mm)

*The Architect must define the distance from the top of the floor/finished floor to top of floor covering so appropriate undercuts can be provided. Floor/Finish Floor is defined as the top of the concrete or structural slab. HMMA uses the term 'top of floor covering' to describe the NFPA term 'nominal surface of floor covering'. Refer to HMMA's TechNote, HMMA-810 TN01-03, "Defining Undercuts", in Appendix 3 for further guidance.*

**END OF SECTION**

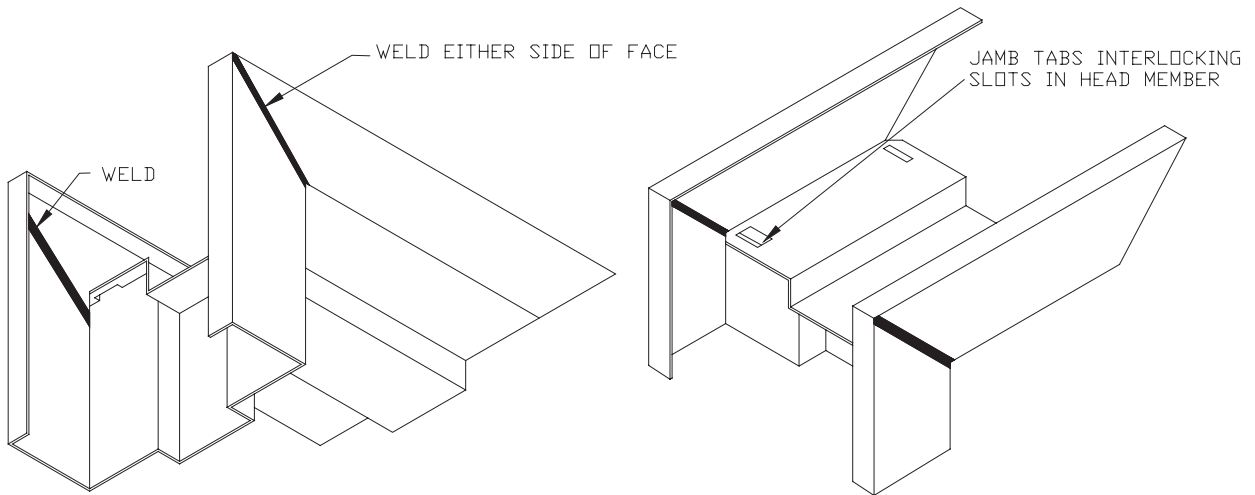

FACE WELDED CORNER JOINT

NOTE: Joint design may vary, see HMMA-820 "Hollow Metal Frames" for representative corner joint details

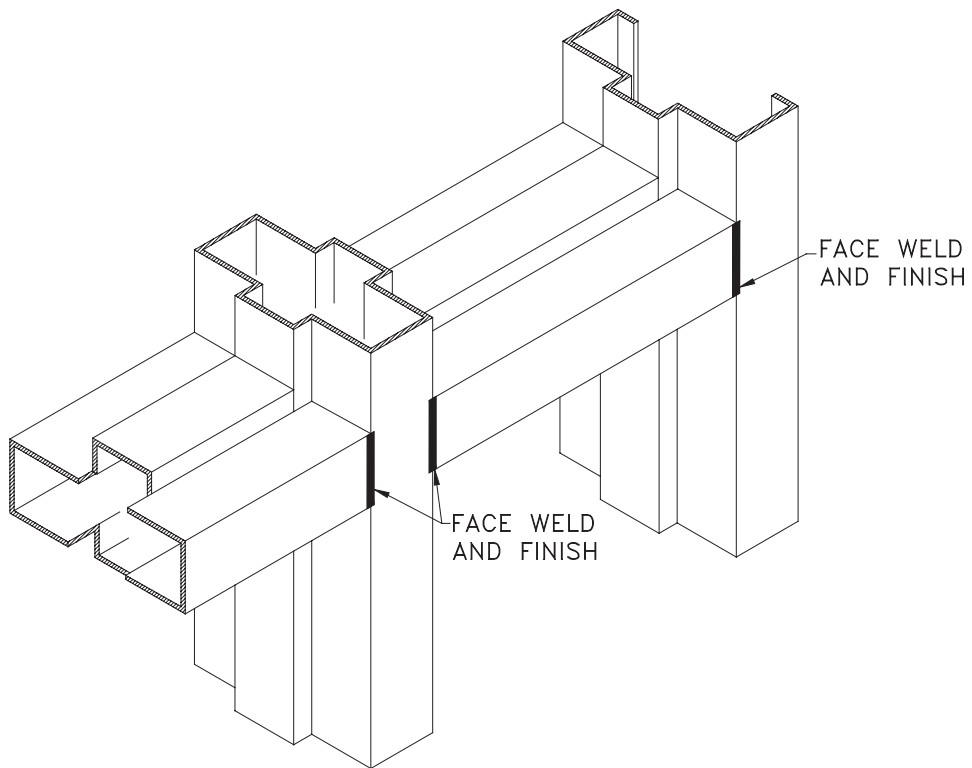

BUTTED AND FACE WELDED JOINTS

Figure 1



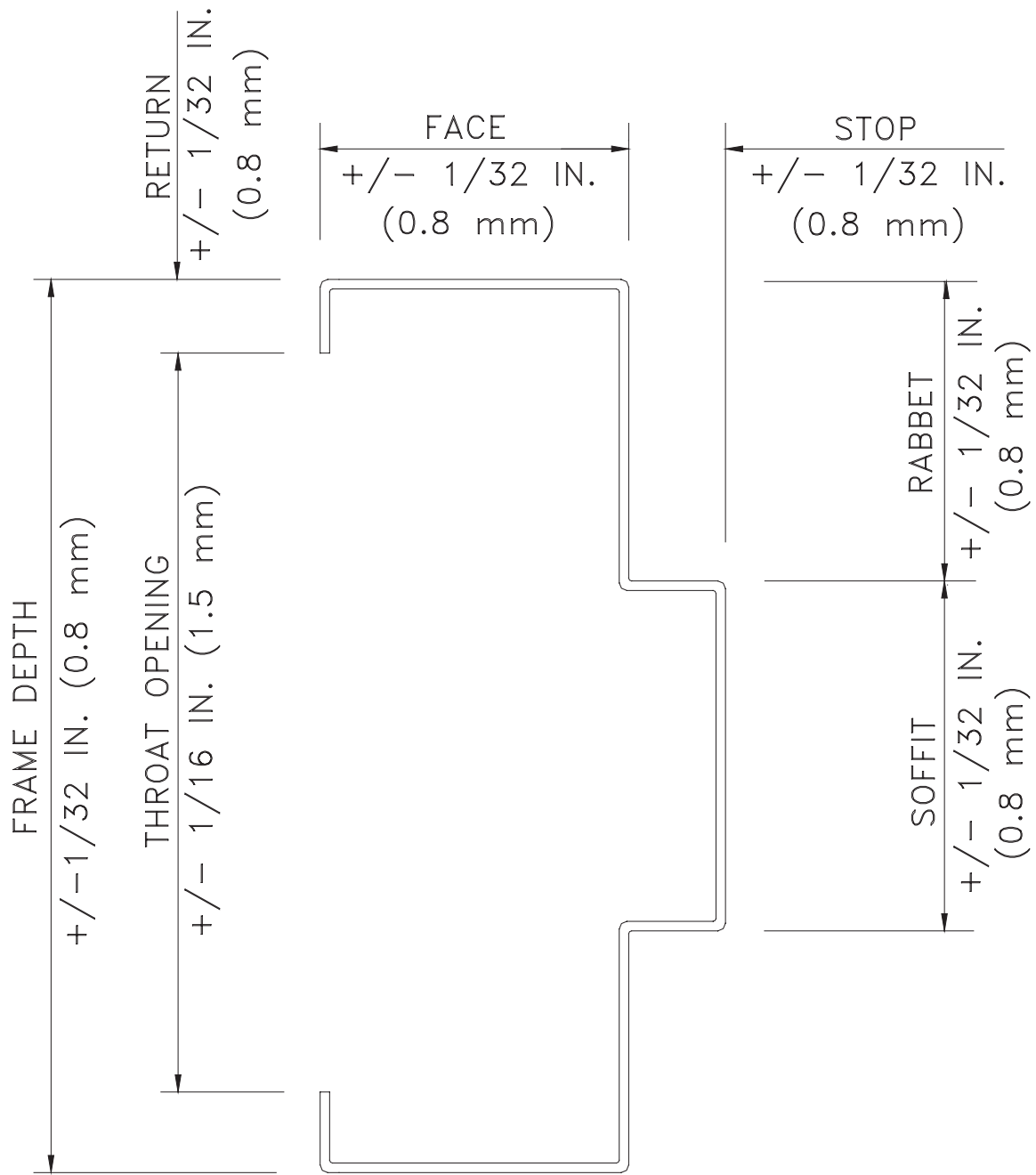

SECTIONAL PROFILE TOLERANCES

**Figure 2**

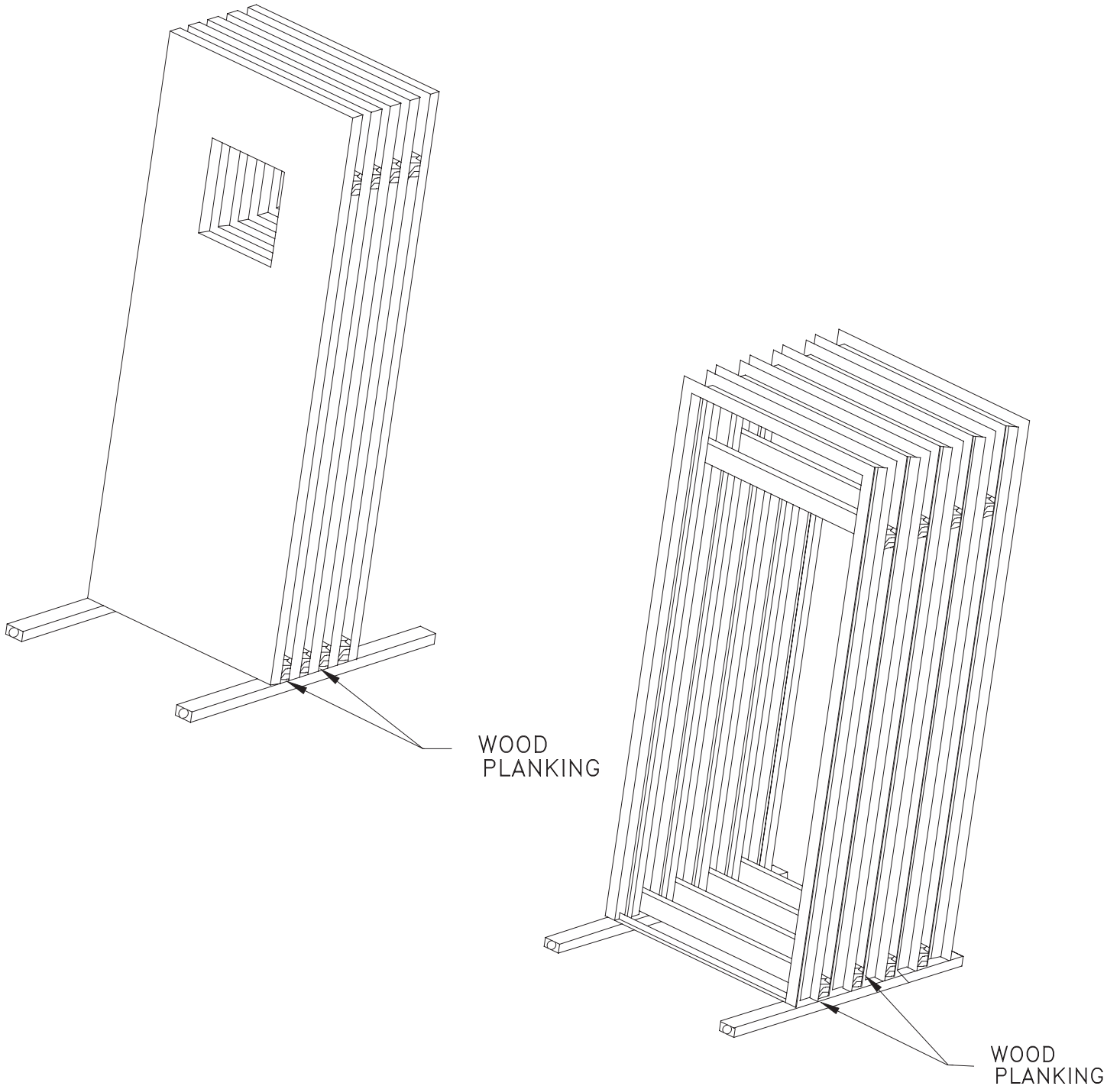

RECOMMENDED STORAGE

**Figure 3**

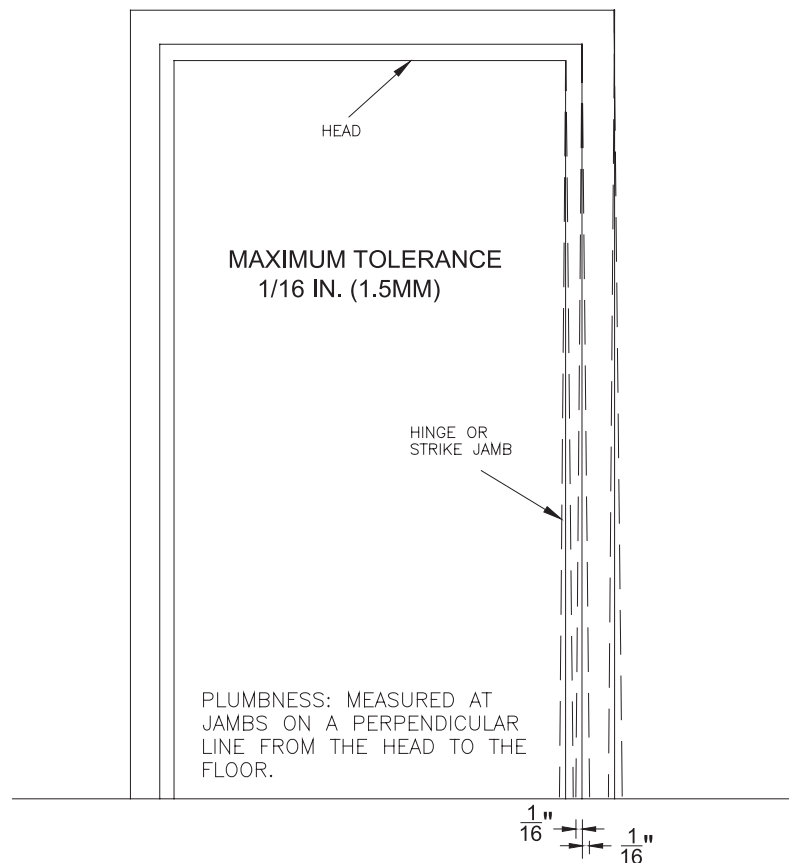
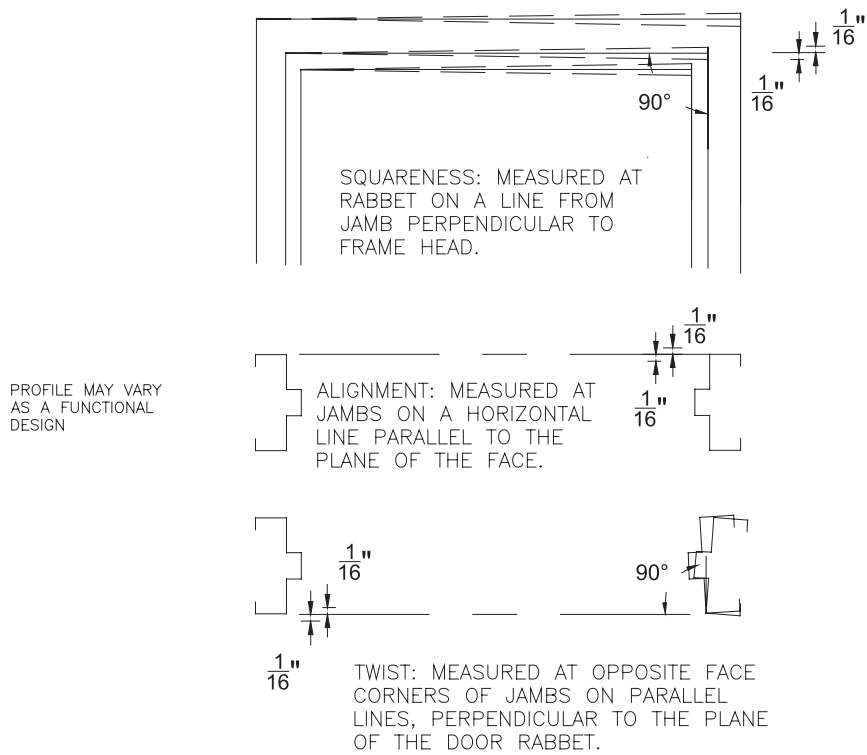

**Figure 4**

**APPENDIX 1**  
**(Not part of the Standard)**

**NAAMM/HMMA 803-97 - STEEL TABLES**

Prior to 1970, sheet steel was referred to by gage. ASTM and ANSI currently do not list gage numbers in their standards. Like many generic terms, gage (or gauge) is ingrained in many vocabularies and is misunderstood as a term for thickness. NAAMM is publishing this Minimum Thickness Table to be used instead of discontinued gage numbers.

The values shown were taken from the Underwriters Laboratories, Inc. publication for gage number and equivalent thickness.

<b>MINIMUM THICKNESS</b>		
Uncoated Steel Sheet		
Gage	Decimal	mm
4	0.214	5.4
5	0.199	5.0
6	0.184	4.6
7	0.167	4.2
8	0.152	3.8
10	0.123	3.1
12	0.093	2.3
14	0.067	1.7
16	0.053	1.3
18	0.042	1.0
20	0.032	0.8
22	0.026	0.6
24	0.020	0.5
26	0.016	0.4
28	0.013	0.3

<b>CONVERSION</b>		
Fraction	Decimal	mm
	1.000	25.4
15/16	0.937	23.8
7/8	0.875	22.2
13/16	0.812	20.6
3/4	0.750	19.0
11/16	0.687	17.4
5/8	0.625	15.8
9/16	0.562	14.2
1/2	0.500	12.7
7/16	0.437	11.1
3/8	0.375	9.5
5/16	0.312	7.9
1/4	0.250	6.3
3/16	0.187	4.7
1/8	0.125	3.1
1/16	0.062	1.5

**DISCLAIMER**

This sheet was developed by representative members of the Hollow Metal Manufacturers Association Division (HMMA) of the National Association of Architectural Metal Manufacturers (NAAMM) to provide their opinion and guidance on minimum thickness and metric equivalents used for hollow metal doors and frames. This sheet contains advisory information only and is published as a public service by the HMMA Division.

NAAMM AND ITS HMMA DIVISION DISCLAIM ALL LIABILITY OF ANY KIND FOR THE USE,  
APPLICATION OR ADAPTATION OF MATERIAL SHOWN ON THIS SHEET

**HMMA** Hollow Metal Manufacturers Division of the  
National Association of Architectural Metal Manufacturers **NAAMM**

**APPENDIX 2**  
**(Not part of the Standard)**

**GROUTING HOLLOW METAL FRAMES**  
**HMMA-820 TN01-03**

Grout, when used in accordance with industry guidelines, can improve frame durability, sound deadening and, depending on wall construction, increases frame anchorage strength. Grouting of the frame does not increase door durability, nor is it required for fire-rated frames. For most commercial applications, grouting of mullions and other closed sections is not recommended.

For applications covered by ANSI/NAAMM HMMA 862, "Guide Specifications for Commercial Security Hollow Metal Doors and Frames", and ANSI/NAAMM HMMA 863, "Guide Specifications for Detention Security Hollow Metal Doors and Frames", the standards require that "frame jambs shall be fully grouted to provide added security protection against battering, wedging, spreading, and other means of forcing open the door".

Grout is a water-based product. If not used properly, it can destroy the opening in a very short time. Grout can be either "mortar", which is a masonry mixture of lime, cement, sand and water, or "plaster", a gypsum-based product.

Plaster grout dries with exposure to air. When a frame member is filled solid with plaster grout, only those areas exposed to air will dry and harden, while the center remains wet (uncured). The water remaining in the plaster grout can rust the frame from the inside.

Mortar grout cures by chemical reaction and hardens throughout. Use mortar grout.

Frames are not designed to act as forms for grout. Grout must have a maximum 4 in. slump and be hand troweled in place. Bracing of the frame may be necessary prior to grouting to prevent sagging of the header or bowing of the jamb due to weight or pressure of the grout. Grout should not be installed after gypsum wallboard is installed, as the liquid within the grout will deteriorate the wallboard.

When dictated by temperatures, anti-freezing agents for mortar may be recommended by specifications. These agents can adversely affect metal and all surfaces in contact with grout must be coated with a corrosion resistant material.

It is recommended that the contractor be responsible for the grouting and for any additional barrier coating. It is also the contractor's responsibility to use care in the application of the grout.

## APPENDIX 3 (Not part of the Standard) DEFINING UNDERCUTS HMMA-810 TN01-03

Review of established definitions.

1. **“ACTUAL DOOR HEIGHT”** - The door opening height minus top clearance and undercut.
2. **“DOOR OPENING HEIGHT”** - The distance measured vertically between the frame head rabbet and top of floor or bottom of frame minus jamb extension.
3. **“FINISHED FLOOR”** - See “Floor”
4. **“FLOOR”** - The top of the concrete or structural slab.
5. **“FLOOR CLEARANCE”** - The distance between the bottom of the door and the top of the material directly below the door. This varies with application, such as concrete, any floor covering and/or a threshold.
6. **“FLOOR COVERING”** - Any material applied on top of the floor that extends under the door in its closed position or under the door as it swings to its fully open position.
7. **“UNDERCUT”** - The distance between the bottom of door and the bottom of frame. The formula in which to determine Undercut is derived by adding the total sum of the following (Floor Clearance + Floor Covering Thickness + Threshold Height (assuming the threshold is mounted on top of the floor covering) + Jamb Extensions Height).
8. **“JAMB EXTENSIONS”** - That portion of a jamb or mullion which extends below the level of the floor.

Typically frames are intended to be installed directly on the floor. When no floor coverings or thresholds are used, the dimension for “Undercut” is the same as for “Floor Clearance”. See Figure # 1.

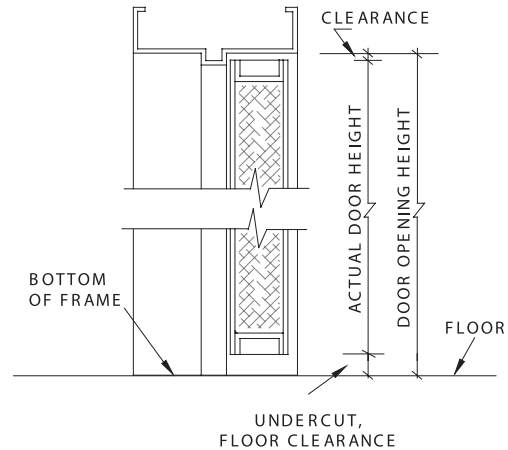

Figure # 1

Floor coverings; such as carpet, resilient or ceramic tile, are typically installed on top of the floor, fitted around the frame, and under the door. In this situation, the formula for figuring Undercut is the total of the Floor Clearance + Floor Covering Thickness. See Figure # 2.

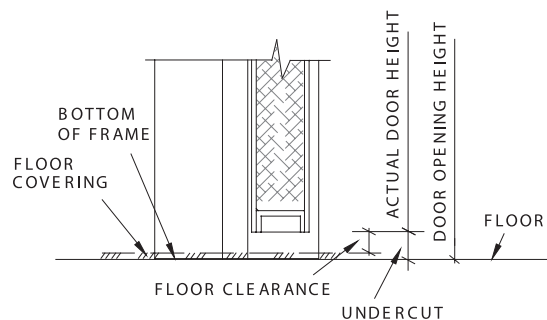

Figure # 2

When a threshold is used, it is installed on top of the floor or floor covering, fitted around the frame and under the door. Again the formula for figuring “Undercut” changes. Undercut is the total of the Floor Clearance + Threshold Height + Floor Covering Thickness. See Figure # 3.

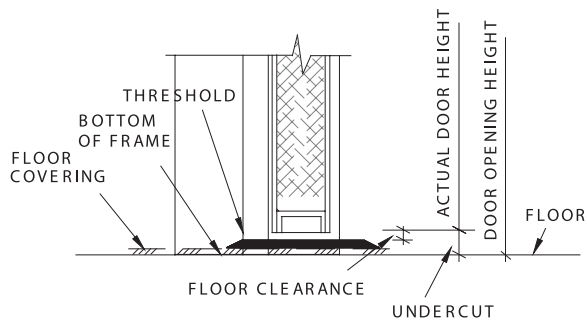

Figure # 3

In situations with specialized floors such as thick ceramic tile or terrazzo, the frame is typically installed prior to the installation of the floor.

One method is to install the frame with adjustable floor anchors or for the frame to be installed on a block or shim. This allows the frame to be positioned, as required, to accommodate the floor height. See Figures # 4A and 4B. Both illustrate a raised frame condition in which the bottom of frame is positioned to be directly on top of the floor after the floor is installed. In this situation, the dimension measured for Undercut is also the same as Floor Clearance.

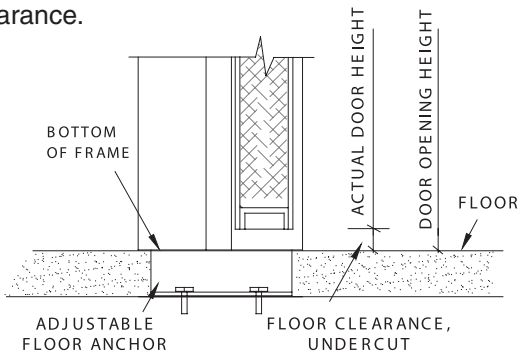

Figure # 4A

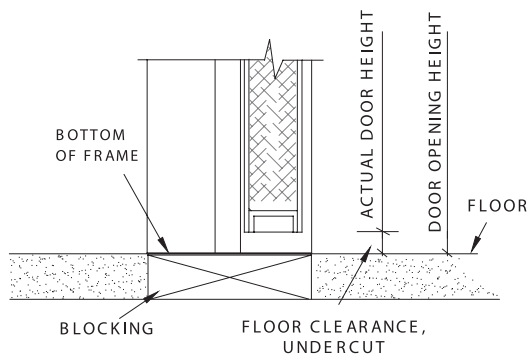

Figure # 4B

Another method, called “below floor installation”, is to install the frame directly on the rough slab. After the frame is installed, the floor is then installed

around the frame. That portion of the frame is covered by the floor and is called jamb extensions. The formula for figuring “Undercut” is the total of the Floor Clearance + Jamb Extensions. See Figures # 5A and 5B.

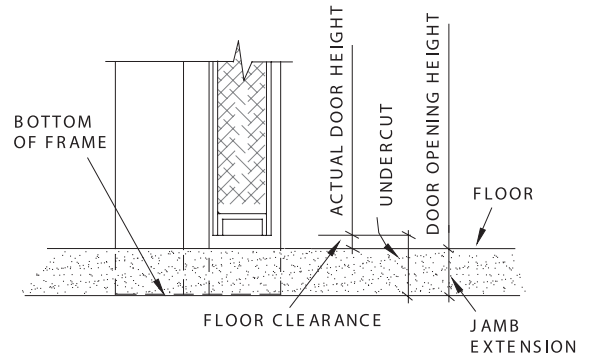

Figure # 5A

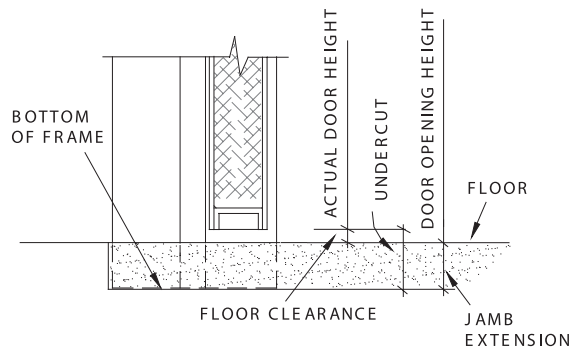

Figure # 5B

The Architect/Designer must be very specific within specifications and contract drawings, which should include detailed drawings illustrating conditions for each floor, including thicknesses and materials. These drawings should designate the height at which the hollow metal frame should be set. Thresholds and hardware items requiring specific floor clearances shall be listed in the hardware schedule, which allows the door and frame manufacturer to properly size each opening.

Within the door and frame industry, both the Hollow Metal Manufacturers Association (HMMA) a division of the National Association of Architectural Metal Manufacturers (NAAMM) and the Steel Door Institute (SDI), publish recommended clearances. In addition, the National Fire Protection Association (NFPA) Publication 80, “Standard for Fire Doors and Fire Windows”, regulates the installation and maintenance of labeled openings, and lists several different scenarios consisting of different floor materials and the maximum clearance under the bottoms of doors.



## APPENDIX 4 (Not part of the Standard)

### THERMAL INSULATING VALUES FOR DOOR CORE MATERIALS

The following table provides Architects and Specifiers with basic insulating performance values for hollow metal laminated door core materials that may be used in exterior doors. It provides the user with the performance levels of the cores only, at their installed thickness, and cured for 180 days.

Real world installations bring into the equation, a multitude of variables which are beyond the control of the hollow metal door manufacturer, and cannot be reflected in assembly tests performed in the controlled environment of a laboratory.

CORE MATERIAL	MINIMUM DENSITY		MINIMUM R-VALUES		MAXIMUM U-VALUE		MAXIMUM K-VALUE <sup>(*)</sup>	
	Imperial (lbs/ft <sup>3</sup> )	Metric (kg/m <sup>3</sup> )	Imperial (degrees F x hours x ft <sup>2</sup> /BTU)	Metric (degrees K x m <sup>2</sup> /W)	Imperial (1/R)	Metric (1/RSI)	Imperial (1/(R ÷ core thickness))	Metric (1/(RSI ÷ core thickness))
Polystyrene	1	16	R 6.0	RSI 1.06	0.167	0.943	0.276	39.7
Polyurethane	1.8	29	R 8.7	RSI 1.54	0.115	0.649	0.190	27.3
Polyisocyanurate	2	32	R 9.9	RSI 1.75	0.101	0.571	0.167	24.0

\*1: K-Value is expressed per inch (or millimeter)

The need for added security or other functional priorities may over-ride the thermal performance provided with the use of these cores. In such instances, honeycomb and steel stiffened doors may be specified for exterior applications.

All cores are not available from all manufacturers or in all areas. Users are encouraged to contact member manufacturers to determine availability and applicability for their specific requirements.



## **RECOMMENDED GUIDE SPECIFICATIONS FOR HMMA HOLLOW METAL DOORS AND FRAMES**

**HMMA 860 — Hollow Metal Door and Frames**

**ANSI/NAAMM**

**HMMA 861 — Commercial Hollow Metal Doors and Frames**

**ANSI/NAAMM**

**HMMA 862 — Commercial Security Hollow Metal Doors and Frames**

**ANSI/NAAMM**

**HMMA 863 — Detention Security Hollow Metal Doors and Frames**

**ANSI/NAAMM**

**HMMA 865 — Swinging Sound Control Hollow Metal Doors and Frames**

**ANSI/NAAMM**

**HMMA 866 — Stainless Steel Hollow Metal Doors and Frames**

**ANSI/NAAMM**

**HMMA 867 — Commercial Laminated Core Hollow Metal Doors and Frames**