

Reversible Doors for Metal Buildings

- SERIES S20-4 (1-3/4" POLYSTYRENE CORE)**
- SERIES P20-4 (1-3/4" POLYURETHANE CORE)**
- SERIES H20-4 (1-3/4" HONEYCOMB CORE)**

SPECIFICATIONS

Doors shall be furnished by **PREMIER** Products, Inc., Monroe, LA, fabricated from minimum spangle hot dipped smooth or textured Galvannealed steel, mill treated for proper paint adherence. Door steel shall be smooth surface for prime painted doors and leather grain textured for pre-finished doors.

SERIES S20-4 Reversible doors shall have a pre-foamed polystyrene slab of 1.0# test density filling the inside of the door. The core shall be secured to the face sheets with adhesive. "U" Factor = .153c - "R" Factor = 6.54c.

SERIES P20-4 shall have a foamed-in-place urethane core that completely fills the inside of the door. The core shall be closed cell and waterproof. "U" Factor = .079c - "R" Factor = 12.64c.

SERIES H20-4 Doors shall have honeycomb cores. The honeycomb core shall be 99# test impregnated with water resistant resin and shall have a crush strength of 55 psi. The core shall be secured to the face sheets with an adhesive. "U" Factor = .42c - "R" Factor = 2.38c.

Reversible doors shall have 20 gauge Galvannealed face sheets with top and bottom channels closed flush. The lock edge

reinforcement shall be 14 gauge. Each hinge reinforcement shall be 9 gauge steel minimum projection welded in six places.

Doors shall be beveled 1/8" in 2" on lock edge for neat fit and security with 1/8" clearance at head, 3/32" clearance at jams, 1/4" clearance at meeting edges of pairs and 3/4" floor clearance.

Standard hardware preparations are 4-1/2," x 4-1/2," (.134) standard weight hinges, conforming to ANSI A156.7 and ANSI A115.1 for Series 1000 mortise locks (Gov. 86) or ANSI A115.2 for Series 4000 cylindrical locks (Gov. 161). Other hardware reinforcements are available upon request.

All doors shall be chemically treated with a metal prep wash primer to produce a long lasting surface.

All pre-finished White or Bronze textured doors shall be packaged with a polybag and fully cartoned to protect the finish. Each door shall then be banded in three places. Part Number and Description shall be placed on leading edge, approximately center line from top and bottom of door. Doors shall be palletized in lots of 20 doors per pallet for shipment and storage.

NOTE: We reserve the right to make changes in specifications, construction, design and details, without notice, at time in such manner as we deem necessary.

Reversible Galvannealed Steel Doors

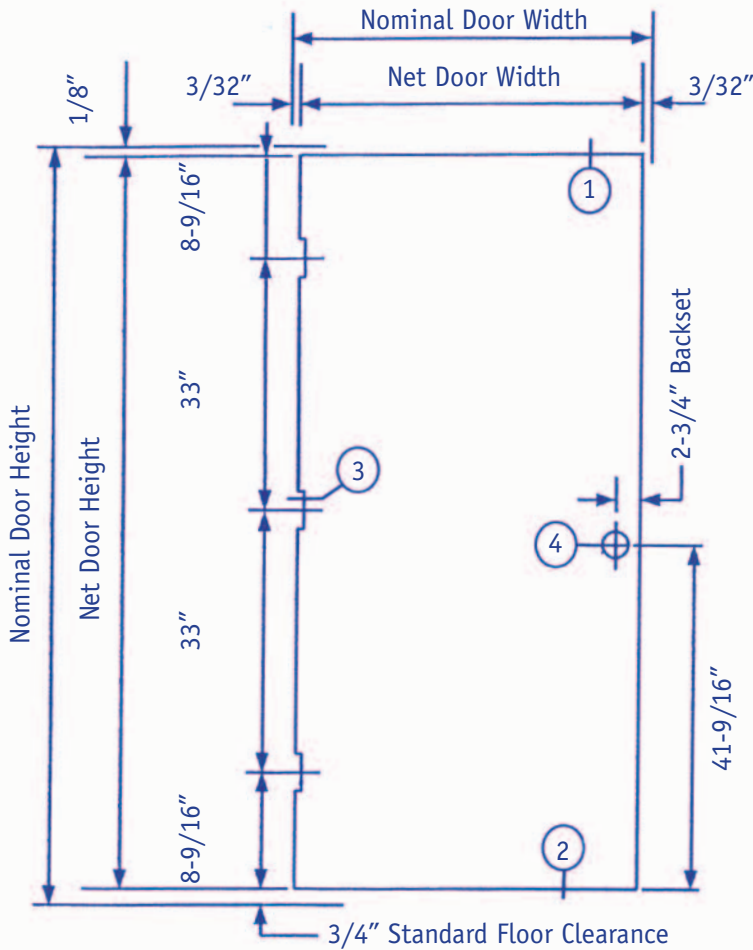

3070 STANDARD

Why Galvannealed steel should be specified for steel doors:

1. All doors are subject to being scratched and marred by usage over a period of time.
2. A metallic zinc coating affords much better protection to steel than paints. This is because other coatings cannot provide anodic protection. That is, if the protective surface is broken and the bare steel exposed, metallic zinc will protect the exposed steel over a considerable area of bare surface. Other coatings can protect only the metal they cover.
3. Also, most door skins are only painted on the exterior and therefore non-galvannealed steel doors can rust from the inside-out.

HARDWARE PREPARATIONS

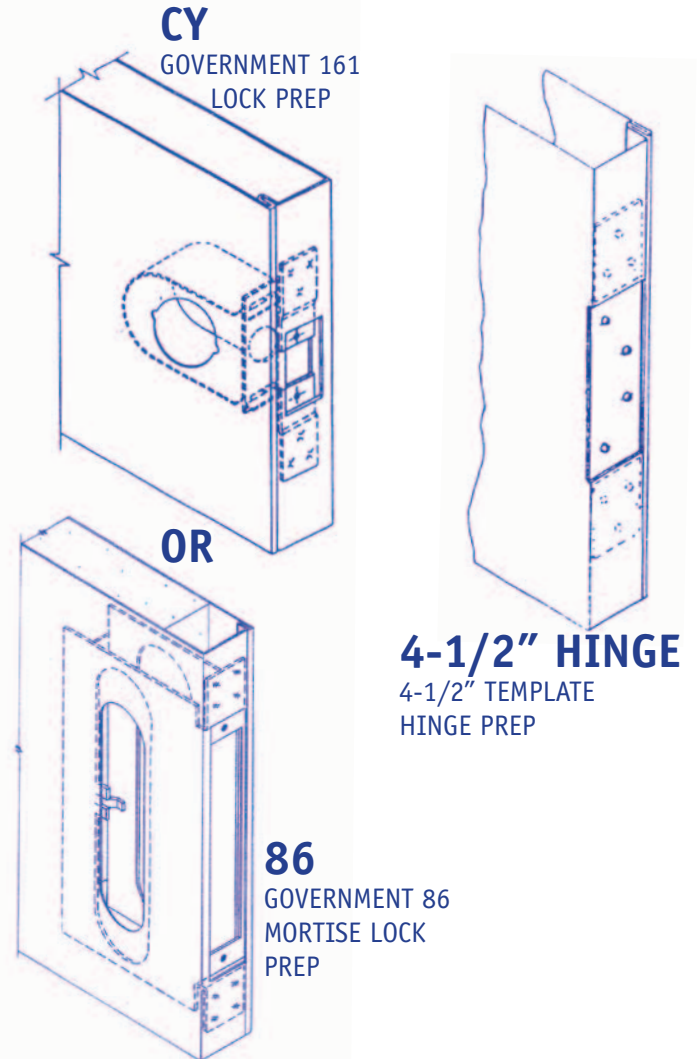

OPTIONS:

- Smooth or leather grain textured steel
 - Grey prime, white or bronze paint
 - Polystyrene, Polyurethane, or Honeycomb
 - Sizes 3070, 4070 single
6070, 8070 double
- Other options available upon request

PREMIER SERIES

Standard Design

Factory Glazing with 3/16" clear tempered glass, single or insulated available.

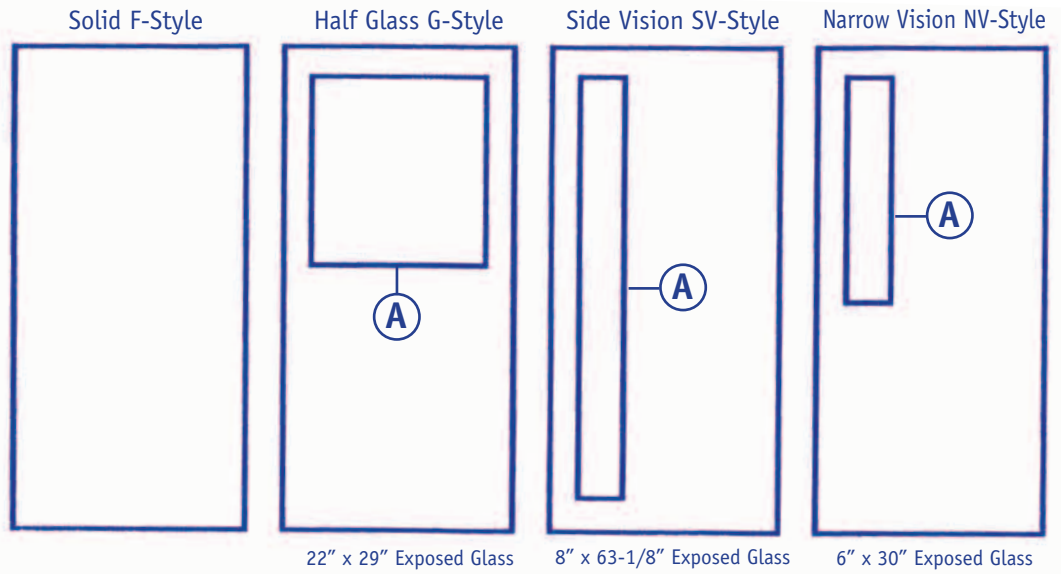

DOUBLE DOORS

Double doors are achieved by selecting two (2) single doors and attaching an astragal (detail B) to close the gap between doors. A cylindrical hole filler enables you to use 2-CY type doors from stock for this application.



FIRE RATED DOORS AND FRAME ASSEMBLIES ARE AVAILABLE UPON REQUEST.

SCREWLESS GLAZING

Aluminum glazing system (min. .040 wall thickness) with screwless bead that fits flush with trim as shown. Factory glazed with 3/16" clear tempered glass, other glazing available.

