

## *Reversible Frames for Metal Buildings*

### SERIES F-16-4 (1-3/4" 16 GAUGE)

#### SPECIFICATIONS

Reversible Metal Building Frames shall be furnished by **PREMIER** Products, Inc., Monroe, LA, fabricated from 16 gauge minimum spangle hot dipped Galvannealed steel mill treated for proper paint adhesion. Bends will be brake formed to assure true, sharp radii and to minimize camber.

Series F16-4 Reversible Metal Building Frames shall receive a modified alkyd primer utilizing a dip process to insure complete coverage. Pre-finished frames are to receive a primer base, plus finish coat providing a double thickness of protection.

Head and jamb corner brackets shall be projection welded to frame members and prepunched for field assembly with 5/16" bolts, providing a simple rigid frame connection.

Series F16-4 Reversible Metal Building Frames consist of three pieces, including the bolts and nuts required for assembly. All necessary reinforcements, clips, and anchors will be welded at the factory prior to shipment.

Standard hardware preparations for Series F16-4 Reversible Metal Building Frames will be 3 - 4-1/2" (.134) standard weight hinges and an ANSI A115.1 or A115.2 (4-7/8") universal strike. Each of the hinge reinforcements will be 9 gauge steel projection welded to the frame in six places.

All pre-finished Metal Building Frames will be packaged in a cardboard carton. Hinge, Strike and Head will be interleaved with microfoam the full length of the carton to prevent damaging the finish. Hardware and / or accessory items will be placed in the head section. The carton will be banded in three places. End flaps will have identifying Number and the Description of the contents. Cartons will be palletized in modules of 20 per pallet (10 High and 2 Deep) with entire pallet being banded in three places for shipment and storage.

A complete technical service is available to metal building manufacturers. Let a **PREMIER** professional assist you in designing a walk door system which is tailored to your needs.

**NOTE:** We reserve the right to make changes in specifications, construction, design and details, without notice, at any time in such manner as we deem necessary.

# PREMIER SERIES

## Reversible Galvannealed Steel Frames

### 3070 STANDARD

STANDARD SIZES  
AVAILABLE

3070, 4070, 6070, 8070  
OTHERS AVAILABLE  
UPON REQUEST

### TYPICAL ELEVATION

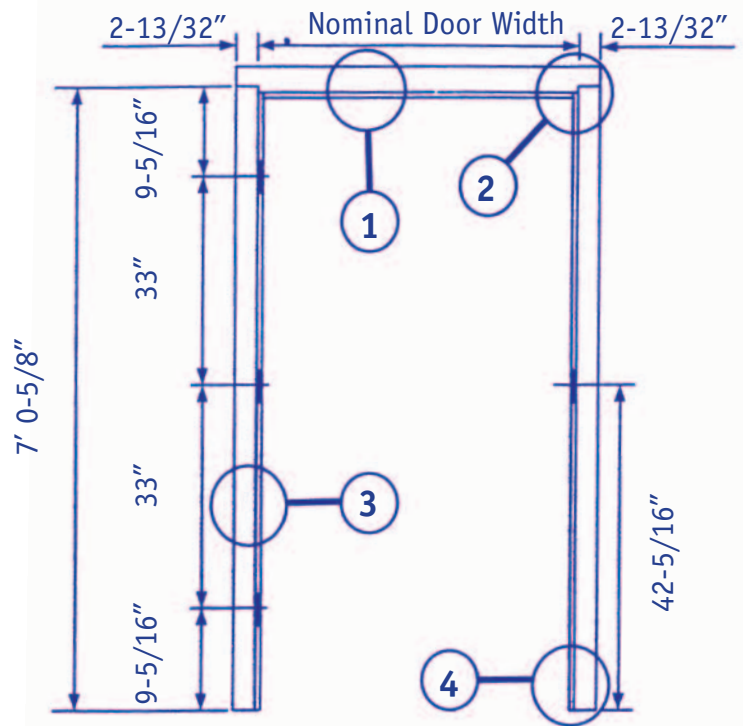

### OPEN-BACKED FRAME

### REVERSIBLE 5-3/4" FRAME

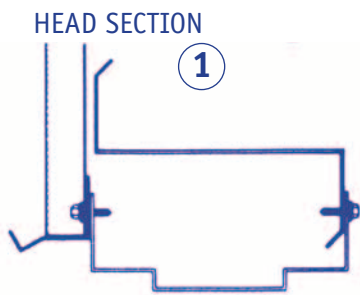

HEAD JAMB CONNECTION

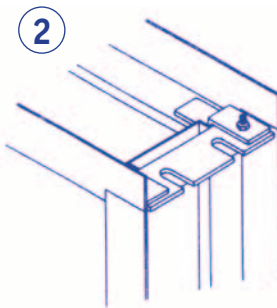

HEAD/JAMB CONNECTION

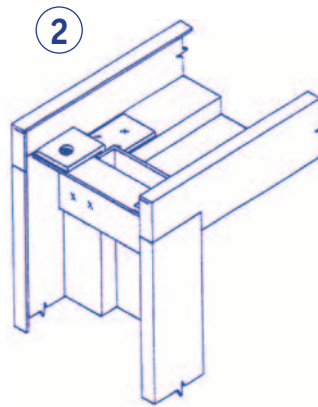

SUB JAMB CONNECTION

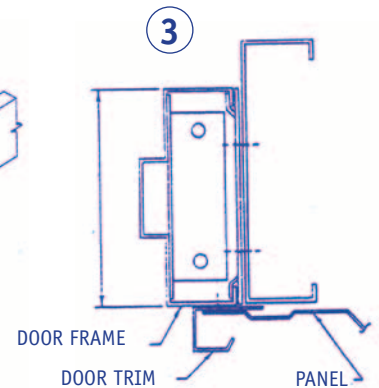

INTERMEDIATE GIRT CONNECTION

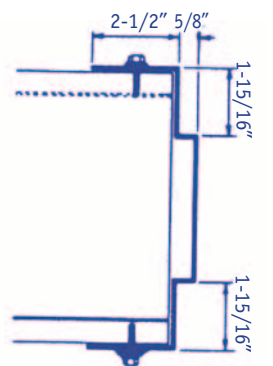

SILL ANCHOR

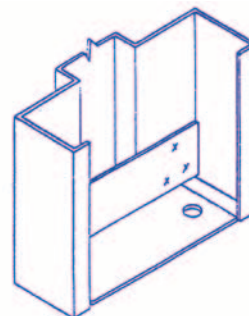
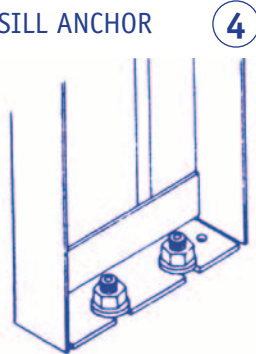

SILL ANCHOR

## HARDWARE PREPARATIONS

### HINGES



9 GAUGE HINGE REINFORCEMENT  
WITH 4-1/2" X 4-1/2" FULL MORTISE  
HINGE PREPARATION

### STRIKES

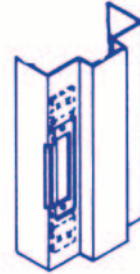

14 GAUGE STRIKE REINFORCEMENT WITH  
ANSI A115.1 OR A115.2 UNIVERSAL STRIKE  
PREPARATION (4-7/8" HIGH)

### FRAME DEPTHS AVAILABLE

4-1/4"

5-3/4"

6-1/4"

7-1/4"

8-1/4"

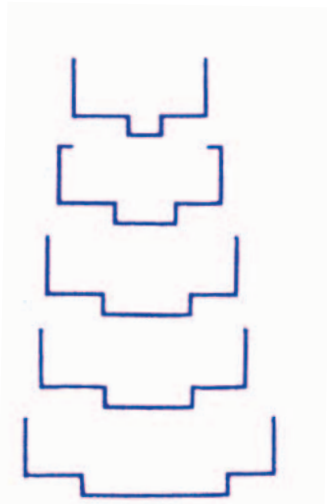

OTHER PROFILES AND  
DESIGNS AVAILABLE  
UPON REQUEST

### JAMB EXTENSIONS

FOR FRAME ATTACHMENT  
TO GIRTS OVER  
7'2" IN HEIGHT

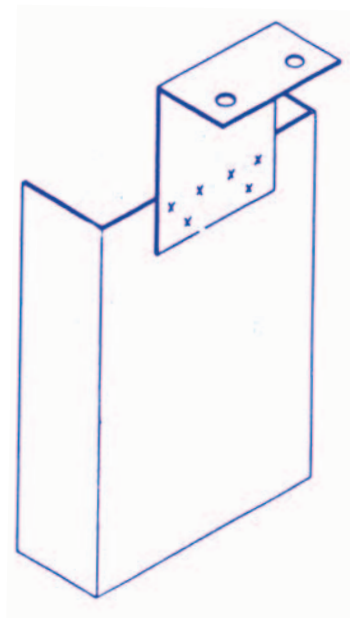

### SUB JAMB MOUNTING

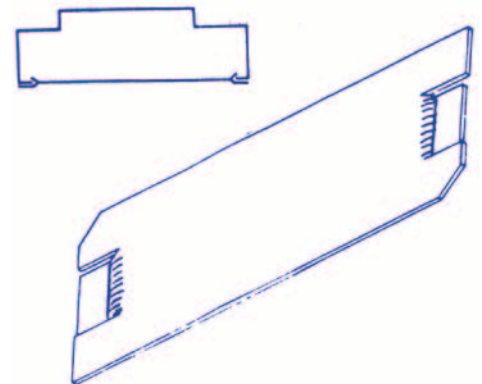

TWIST IN PLATE FOR  
FLUSH MOUNTING TO  
SUB JAMBS

# ERECTION INSTRUCTIONS FOR PREMIER SERIES REVERSIBLE FRAMES

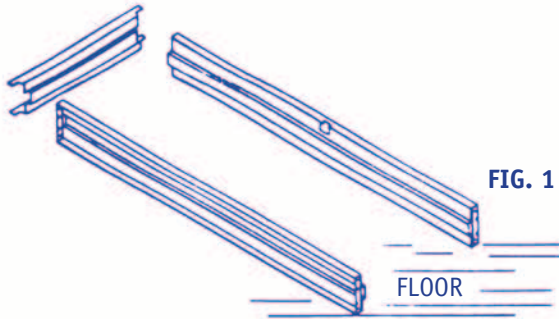

**STEP I** Place head Section and Jambs on flat surface (floor) with Door side up. (See Fig. 1) Install Bolts and Nuts connecting Head to Jambs. Be sure that Head is tight to Jambs so that the proper Door Opening is obtained. EXAMPLE: 3'0" Door requires a 36" Frame Opening. (See Fig. 2)

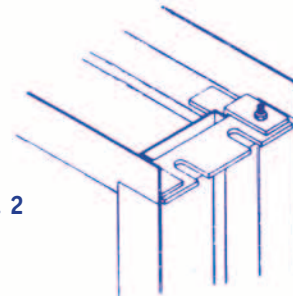

**STEP II** Install Pre-Notched Threshold, utilizing the Spring Clips which are already installed in the Threshold (See Fig. 3)

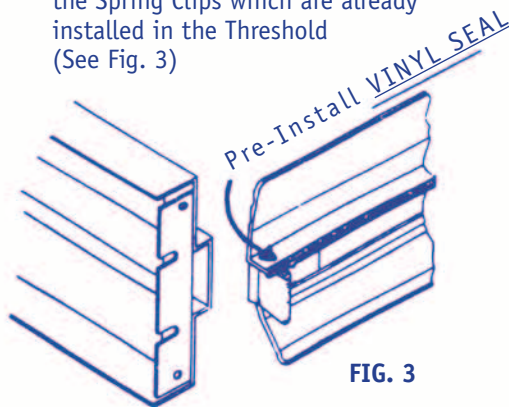

**STEP III** Install Door in Frame, check for 1/8" clearance at Head and 3/32" clearance at Strike Jamb. (See Fig. 4)

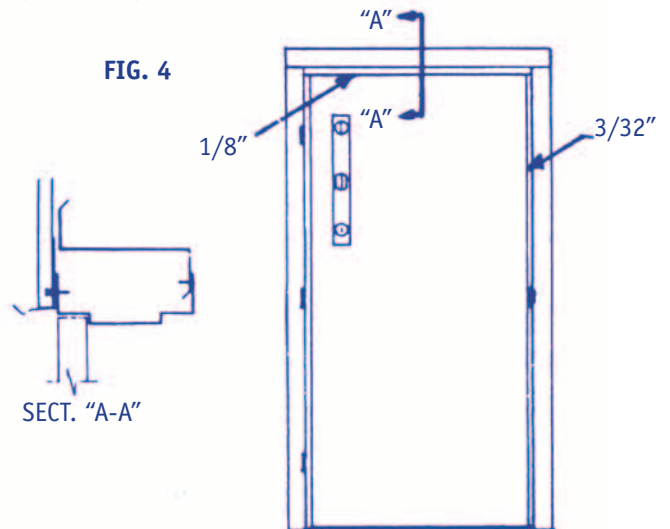

**STEP IV** Tilt up the entire assembly and secure Hinge Jamb Anchor to floor. Plumb Hinge Jamb and Assembly.

**NOTE:** Steps III and IV may be reversed at option of erector.

**STEP V** Anchor Head and Strike Jamb to Building Structure, Floor and entire Frame to Panel Skins. Install Optional Threshold Anchor if desired. (Not a part of Single Opening package.)

**PREMIER** provides a complete total openings package that includes the walk door, frame, hinges, thresholds, locksets and weatherstripping.

## REGIONAL SALES OFFICES & WAREHOUSES

### ◆ Atlanta

Oakridge Business Park  
6945 Oakridge Parkway  
Suite 207  
Austell, GA 30168  
(770) 944-1006  
FAX (770) 944-0963

### ◆ Houston

4660 Pine Timbers  
Suite 126  
Houston, TX 77041  
(713) 690-0435  
FAX (713) 690-8241

### ◆ Monroe

2840 Sterlington Rd.  
(HWY 165 North)  
Monroe, LA 71203  
(318) 361-0796  
FAX (318) 323-5068

### ADMINISTRATIVE OFFICES MANUFACTURING FACILITIES & CUSTOMER SERVICE:

2840 Sterlington Rd.  
(HWY 165 North), Monroe, LA 71203  
PH. (318) 361-0796  
FAX (318) 323-5068

**PREMIER** Products, Inc. | P.O. Box 7269 | Monroe, LA 71211

**318.361.0796 | FAX 318.323.5068**